



**EUROPEAN
CHAMPION**

**USA
CHAMPION**

**AWARD-WINNING
RC CAR DESIGNER**

LUXURY MODEL RACING CARS



EUROPEAN CHAMPION



To win a club race, European Championship, or USA Championship, you need a car you can trust and rely on in any racing condition. With high praise and numerous awards around the world, XRAY model racing cars constantly live up to their winning heritage... the spirit of racing... the pedigree of a true champion.

XRAY — the champions' choice — your choice.



USA CHAMPION



1/8 OFF-ROAD BUGGY

1/10 ELECTRIC TOURING CAR

RC RACING TEAM XRAY

Team XRAY is one of the world's most successful racing teams, with an extensive list of wins and achievements. Owning an XRAY product, you become a member of the worldwide network of national teams, receiving special and exclusive product support and service like the PRO drivers do. Racing an XRAY car, you can be on your way to becoming another valued member of XRAY's International Factory Team, maybe even winning a European or US Championship! Challenge your skills...enjoy the XRAY ride.



11x USA National Champion European Champion Multiple National Champion World Wide Team XRAY at International Indoor Championship 2006

The world of XRAY is one of excitement, prestige, luxury, and adrenaline-charged performance. XRAY's impressive product line offers premium quality, innovative engineering marvels and the exclusivity borne of success on the world's racetracks, a marriage of **sophistication, luxury, craftsmanship, and leading technology**. Owning an XRAY is being part of the team...the same team that has dominated races all over the world for years. XRAY and its products embody a genuine sporting spirit as well as distinctive European styling, design and quality. While we always look to the future, we will never lose sight of the values that have made XRAY what it is today... **passion, dedication, and commitment to excellence**. It's no wonder that XRAY is the top RC manufacturer in the world, backed up with the impressive list of accomplishments, awards, and wins.

XRAY
THE ART OF PERFORMANCE.
PRESTIGE. ELEGANCE. LUXURY.



XRAY's wins and accomplishments are too numerous to completely list. Aside from many others, here are the Team XRAY wins from 2006 alone:

- 1/10 Electric Touring car:**
- World Cup Winner
 - French National Champion - Sport
 - European Champion - Junior
 - EFRA GP Winner
 - DHF Cup Vice-Champion
 - LRP Masters Winner - Stock
 - LRP Masters Winner - 19T
 - Orion Speed Weekend Winner - 19T
 - Ready Race USA Winner
 - Portugese National Champion
 - US TC Nationals 2007 Champion - Expert
 - US TC Nationals 2007 Champion - Stock
 - US TC Nationals 2007 Champion - Brushless
 - US TC Nationals 2007 Champion - 19T Foam
 - US TC Nationals 2007 Champion - Stock
 - DHI Cup 2007 Winner - Stock
- 1/8 Off-road Nitro Buggy:**
- European Champion
 - Nordic Champion
 - French National Champion Expert
 - Danish National Champion
 - Swedish Off-road Cup Winner
 - Portuguese National Champion
 - Bulgarian National Champion
 - Czech National Champion
 - Polish National Champion
 - Russian National Cup Winner
 - Slovak National Champion
 - French National Champion Stock
 - Canadian Winter Nationals Winner
 - Chinese National Champion
 - Singapore Off-road GP Winner
 - New Zealand National Champion
 - German Juvenile National Champion
 - EFRA GP Winner
 - Novarossi GP Cup Winner
 - Proline Dirt Indoor Challenge Winner
 - UK Vice-Champion
 - Canadian Winter Nationals Champion
- 1/18 Micro Car:**
- US National Champion

Car of the Year 2001, Car of the Year 2002, Car of the Year 2003, Car of the Year 2004, Car of the Year 2005, Car of the Year 2006, World's Best Crafted Touring Car Award, World's Best Touring Car Award, World's Best Belt Driven Touring Car, World's Best Off-Road Car 2004, Buggy of the Year 2006, Reader's Choice Award, Best of 2006

World's Best Touring Car Award Readers' Choice Award 2006 Results

LUXURY PURE RACING DESIGN
PREMIUM QUALITY
HIGHEST PERFORMANCE
LOWEST CG



NTM
1/10 LUXURY NITRO TOURING CAR



CNC-machined 3mm **Swiss 7075 T6** chassis



Radio box with **Quick-Exchange** system for crystal



Optimized nitro touring car suspension geometry



Quick & easy access to rear differential



Quick & easy access to front differential

MULTI FLEX™

Unique new Multi-Flex™ 1-piece engine mounting system allows chassis stiffness adjustment for different racing condition... **another XRAY revolution!**



XRAY MULTI-DIFF™

Available as option only

Unique, revolutionary front XRAY Multi-Diff™ enables 3 different easy settings:

- one-way
- one-way solid
- full-time solid axle



XCA CLUTCH



Easily-adjustable 3-shoe XCA (XRAY Centrifugal-Axial) clutch featuring clutchbell, clutch nut and preload collar made from exclusive **Hudy Spring Steel™**, hardcoated flywheel, clutch nut, preload collar, shoe support plate and spring cup made from premium **Swiss 7075 T6**.

2-SPEED



Precision, super-smooth 2-speed transmission features **HUDY®** shaft, **Swiss 7075 T6** gear adapters, hand-ground German 1-way and world's most precise wobble-free spur gears

LOWEST CG



NT1 features all the parts positioned ultra low creating the lowest CG platform. Low fuel tank can be lowered by another 3mm using optional tiny receiver pack.

HIGH-PERFORMANCE PARTS



Exclusive **Hudy Spring Steel™** drive shafts front & rear



Premium **Hudy Spring Steel™** adjustable turnbuckles



Quick-set 2-piece aluminum engine mounting system



Hudy Spring Steel™ wheel axles and diff outrives



4-step externally-adjustable racing shocks w/ selected springs



World's smallest, super-smooth, no-slip, high-durability gear differentials



High-speed lightly-oiled selected ball-bearings

• pure racing design, premium luxury quality, and **highest performance** • 2.5 mm graphite radio plate, front shock tower and roll center bridge, 3.0mm graphite rear shock tower • centralized 75cc fuel tank with hypertonic tank lid and internal stone-type filter • 7075 T6 aluminum brake hub with precision-pressed pins • **laser-cut, precision flat-ground** ventilated steel brake disk for ultra-efficient fade-free braking • high-grip **Ferodo™** brake pads • 7075 T6 aluminum ball-bearing supported brake cam • most efficient, smoothest drivetrain using optimum belt and pulley construction with super-low rotating mass • exclusive **Hudy Spring Steel™** drivetrain parts for highest performance and unmatched lifespan • **PUR®** reinforced high-efficiency, low-friction drive belts • specially-designed adjustable graphite side-belt tensioner allows easy engine removal • solid axle diff adapter transforms differential into **solid axle (spool)** • advanced suspension geometry **optimized** and finely tuned for high-competition racing • lightweight yet durable suspension parts molded from XRAY's self-developed composite mixture • fully-adjustable suspension featuring **I.S.S.™** (Integrated Suspension Settings™) • easily-adjustable hand-ground **blade-style** front-anti roll bars from **Hudy Spring Steel™** • precision pivot balls specially hardened for enhanced lifespan • centralized ball-raced steering servo saver with adjustable spring tension • easily-adjustable Ackermann positions using integrated inserts • fine-threaded shock bodies for precise ride height adjustment • **specially-hardened** shock shafts for maximum strength • XRAY **self-developed** and manufactured ultimate racing springs are hand-selected for maximum precision, equal length, and equal damping characteristics





XB8 EC

XB8 EC

CAR OF THE YEAR
2004
2006

**WORLD'S BEST
PREMIUM OPTIMIZED
REFINED**

**EUROPEAN
CHAMPION**

XB8 EC
1/8 LUXURY OFF-ROAD BUGGY

**EUROPEAN
CHAMPION**



CHAMPIONS COMBO

The **European Champion** XB8EC is now also available in an exclusive combo kit with **3x World Champion** RB engine.

Insane power, incredible performance... the best winning combination.



CNC-machined **Swiss 7075 T6** alu radio plate, center diff plate & front upper deck



All **new suspension geometry** features longer front shocks, modified arms and steering blocks



Improved geometry for improved handling on bumpy tracks and big jumps



Front & rear suspension fully adjustable using **I.S.S.™** (Integrated Suspension Settings)

HIGH-PERFORMANCE PARTS

New modified front arms for improved steering and more downtravel



World's lightest, most durable driveshafts hand made from famous **Hudy Spring Steel™**



Swiss 7075 T6 CNC-machined:

- front/rear shock towers (4mm)
- steering plate (3mm)
- front upper deck (4mm)
- radio plate (3mm)
- diff mounting plate (3mm)
- suspension holders (5mm)
- alu engine mounts



Laser-cut, precision flat-ground ventilated steel brake disks



Swiss 7075 T6 CNC-machined hardcoated 3mm chassis

Hardcoated **Swiss 7075 T6** flywheel with lightweight alu clutch shoes



Hardcoated **Swiss 7075 T6** wheel axles and wheel nuts



Exclusive adjustable turnbuckles from **Hudy Spring Steel™**



New modified pivot balls with backstop from **Hudy Spring Steel™**



High-grade special steel clutchbell



New **big-bore** alu shocks



Diff outdrives made from **Hudy Spring Steel™** specially ground for maximum precision



Super-smooth, no-slip, high-durability gear differentials (front, center, rear)



NEW 2007 SPECS:

- **European Champion** (EC) specifications
- improved handling used to dominate and win the European Championship
- new chassis with improved weight distribution
- new & improved front suspension (front arms & steering blocks)
- much more stable handling, easier to drive with more steering
- more downtravel and improved steering throw
- improved handling on bumpy tracks and big jumps
- new center diff mounting allows use of larger spur gears
- new same-length center drive shafts, front & rear
- all new big-bore shocks
- new longer front shocks for improved suspension handling
- new taller **Swiss 7075 T6** front shock tower accommodates longer front shocks
- new interior shock body design prevents piston warpage/breakage
- precision-round shape of pistons for perfect movement inside the shock
- new longer shock rods from special hardened steel
- new shock membranes improve damping
- new **XRAY Premium Shock Oils** for perfect consistency
- new short shock boots with foam dust-protector
- new improved **Hudy Spring Steel™** steering pivot balls for more downtravel
- reinforced front and rear composite braces to prevent tweak
- new **Swiss 7075 T6** radio tray with stylish black/silver edging
- new clutch spring design for improved durability
- 30% stronger servo saver spring for more precise steering
- ultra-lightweight racing body molded from thin **Lexan®**

• premium high-competition off-road buggy • very easy assembly/disassembly and maintenance • efficient C-hub suspension with XRAY's innovative **I.A.C.™** (Integrated Adjustable Caster) • lightweight strong molded steering blocks with molded-in steel bushings • fully-adjustable suspension featuring XRAY's **I.S.S.™** (Integrated Suspension Settings) • ultra-low CG, all parts centralized in chassis • optimized front/rear and left/right weight balance for perfect jumping • **pure racing design**, highest performance and long life, ultra-durable parts • fully independent, fully-adjustable suspension with full-time 4WD • ultra-lightweight high-tensile transmission parts hand made from special world-renowned top-secret self-developed **Hudy Spring Steel™** • drivetrain includes **22 high-speed** rubber-sealed bearings for maximum efficiency and speed • ultra-precision front/rear and center diffs with **Hudy Spring Steel™** outdrives • pinions, spurs, crown gears and clutchbell manufactured by **HUDY®** • all alu parts feature XRAY stylish black with silver edging design • aluminum shocks with 3.5mm rigid shock shafts • optimized multiple upper and lower shock mounting locations for front and rear • laser-cut, precision-ground steel brake disks for ultra-efficient fade-free braking • high-grip **Ferodo®** brake pads • exclusive adjustable turnbuckles from **Hudy Spring Steel™** • front and rear anti-roll bars, fuel filter, set of stylish XRAY wheels included





RUGGED
LUXURY
EXCITING
HERITAGE

PREMIUM TRUGGY
RACING DESIGN

XT8
1/8 LUXURY RACING TRUGGY

UNIQUE
REVOLUTIONARY
C-HUB SUSPENSION



Purpose-designed truggy suspension features reinforced arms to prevent bending



CNC-machined **Swiss 7075 T6** alu front upper deck, radio plate, diff plate and shock towers



XRAY Racing Truggy XT8 is based on the **European Champion** XB8EC off-road buggy



Super-long arms ensure best handling over rough terrain & excellent landing after big jumps

HIGH-PERFORMANCE PARTS

Suspension holders allow complete geometry adjustment



Laser-cut, precision flat-ground ventilated steel brake disks

Super-long arms from special composite mixture for highest durability



Swiss 7075 T6 precision flywheel with alu 3-piece clutch shoe

Premium **Hudy Spring Steel™** adjustable turnbuckles



Special truggy-designed diff gears made from specially-developed **HUDY®** steel for gears

Big bore long alu shocks specially designed for Truggy



Diff outrives made from **Hudy Spring Steel™** specially ground for maximum precision

Super-smooth, no-slip, high-durability differentials with heat-treated gears



17mm **aircraft alu** wheel axles with optimized offset

World's lightest, most durable driveshafts hand made from famous **Hudy Spring Steel™**



High-grade special steel clutchbell

Swiss 7075 T6 CNC-machined hardcoated 3mm chassis

CRUSH COMBO

XT8 is also available in exclusive combo kit with RB Truggy engine with insane and incredible power



LUXURY XRAY DESIGN

Swiss 7075 T6 CNC-machined:

- front/rear shock towers (4mm)
- steering plate (3mm)
- front upper deck (4mm)
- radio plate (3mm)
- center diff plate (3mm)



• XRAY Racing Truggy based on the **European Champion** XB8EC off-road buggy • designed and developed by the world's **most admired** R&D team • pure racing design and premium luxury quality with highest performance • all parts specifically designed and developed for **Truggy-specific** high-performance suspension geometry, specific ultra-efficient drivetrain parts with optimal Truggy ratio • only **premium** and exclusive materials used throughout • exclusive **Hudy Spring Steel™** drivetrain parts for highest performance and unmatched lifespan • efficient C-hub suspension with innovative **I.A.C.** (Integrated Adjustable Caster™) • lightweight strong molded steering blocks with molded-in steel bushings (**XRAY innovation**) • fully adjustable suspension • front upper suspension featuring **I.S.S.** (Integrated Suspension Settings™) • ultra-low CG, all parts are centralized in chassis • optimized front/rear and left/right weight balance for perfect jumping • fully-independent, fully-adjustable suspension with full-time 4WD • ultra-lightweight high-tensile transmission parts hand made from special world-renowned top-secret self-developed **Hudy Spring Steel™** • drivetrain includes 22 precision rubber-sealed bearings for maximum efficiency and speed • ultra-precision front/rear and center diffs with Hudy Spring Steel™ outrives • pinions, spurs, crown gears and clutchbell manufactured by **HUDY®** • all new extra-long big-bore shocks for perfect handling on bumpy tracks and big jumps • all alu parts feature XRAY's stylish black finish with silver edging for luxurious touch • **laser-cut, precision-ground** steel brake disks for ultra-efficient fade-free braking • high-grip **Ferodo®** brake pads • **Hudy Spring Steel™** adjustable turnbuckles • **Swiss 7075 T6** hardcoated flywheel with aluminum clutch shoes • stylish XRAY Truggy body included made from lightweight **Lexan®** • XRAY Thrax Truggy tires, foam inserts and racing dish wheels included



9x
CAR OF THE YEAR

11x
USA
NATIONAL CHAMPION

caraction
Reader's
Choice Award

US SNOWBIRD
Nationals
WINNER
2004-2005-2006

**PREMIUM
QUALITY
REFINED**



OPTIMIZED
PERFORMANCE
EXPERTISE
PRECISION

LUXURY

T2 '007
1/10 LUXURY ELECTRIC TOURING CAR

Paul Lemieux

USA

Paul Lemieux



CHAMPION

XRAY QUICK-SAVER™

Revolutionary fully-adjustable **Quick-Saver™** features 5 different integrated Ackermann positions



World's lowest top deck & lightweight bulkheads



New rear split bulkheads for more rear flex

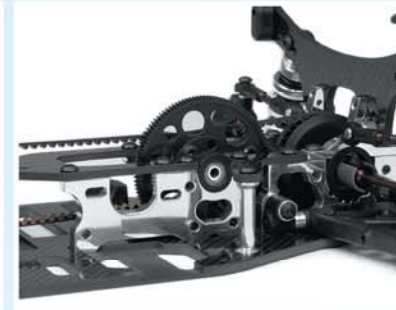

Lowest ultra-lightweight **Swiss 7075 T6** bulkheads



US-spec 3.5mm ultra-thick chassis with milled areas

XRAY DRIVETRAIN CONCEPT



World's Most Efficient Drivetrain

The ultra-efficient drivetrain from the coveted T2 has been carried over into the T2'007. This drivetrain has proven to be the most efficient and effective electric touring car drivetrain system. The inline, super-efficient twin-belt drivetrain features oversized pulleys with optimum 1.7 internal ratio. The race-proven pulleys and drive belts have been carried over from the T1 platform and the super-efficient 20T middle shaft pulley guarantees the best belt wrapping and highly-efficient drivetrain.

XRAY MULTI-DIFF™

Unique, revolutionary front **XRAY Multi-Diff™** enables 3 different easy settings:

- one-way
- one-way solid
- full-time solid axle



LOWEST CG

Long Flex Minimizes Tweak

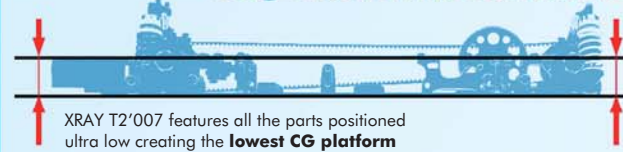

XRAY T2'007 features all the parts positioned ultra low creating the **lowest CG platform**

HIGH-PERFORMANCE PARTS

World's lightest, most durable driveshafts hand made from famous **Hudy Spring Steel™**



4-step externally-adjustable racing shocks w/ selected springs

Exclusive adjustable turnbuckles made from famous **Hudy Spring Steel™**



7075 T6
30% STRONGER



Adjustable ball differential **7075 T6** with carbide balls and carbide axial bearing

Well proven T2 suspension parts provide optimized suspension geometry for maximum performance



Swiss 7075 T6

CNC-machined bulkheads



High-speed blue covered ball-bearings manually selected



CNC-machined **aircraft alu** lightweight main layshaft

MULTI-FLEX™

The invention and release of **XRAY Multi-Flex Technology™** (XRAY patent) has resulted in some of the most significant milestones in touring car development in the past few years, and as such this innovation was not only praised by awards and accolades, but mainly it has been proven as a distinct competitive advantage at racetracks world wide. All helping the T2 to dominate most races at local and national levels.

The all-new revolutionary and innovative approach to car setup and adjustment has undergone very detailed long-term testing and analysis, and has been further developed by the **XRAY Engineering Team**. For 2007, XRAY presents improved and optimized **Multi-Flex Technology™**.



ULTRA STIFF STIFF MEDIUM SOFT

• built on the highly-successful XRAY T2 platform • world's lowest touring car platform • longer top deck design minimizes tweak • XRAY **Multi-Flex Technology™** - fully adjustable chassis and top deck flex and torsion - F1 technology • XRAY Quick Roll-Centers™ • strong aluminum servo stand • famous **XRAY Multi-Diff™**: one-way / one-way solid / full-time solid axle • **Hudy Spring Steel™** turnbuckles • compact front foam bumper made from lightweight, high-resilience foam • small, robust steering blocks made from special composite material, featuring two Ackermann positions • front and rear shock towers CNC-machined from 3mm graphite material with optimized shock positions for rubber and foam tires with optimized **Quick Roll-Center™** positions • world's most efficient drivetrain with 1.7 internal ratio • belt tensioning adjustment in both front and rear bulkheads • all parts are fully compatible with the T2 platform and fully interchangeable between US and EU versions • Rebuildable CVD driveshafts made from world-renowned, top-secret, self-developed **Hudy Spring Steel™** with low-friction drive clips; world's tiniest yet most durable driveshafts hand ground for maximum precision • unique **XRAY Quick-Saver™** with 5 different Ackermann positions • new rear split bulkheads allow more rear flex and improved rear traction • world's lowest ultra-lightweight bulkheads CNC-machined from **Swiss 7075 T6** aluminum • lightweight hollow aircraft aluminum middle layshaft • thick 6mm body posts • front/rear top deck aluminum posts • lower suspension holders with 3 different roll center positions • **7075 T6** aluminum wheel hubs • XRAY 4-step externally adjustable shocks • selected & matched racing springs • complete set of high-speed blue-sealed ball-bearings, degreased, lightly oiled for maximum efficiency, individually controlled, selected and inspected • externally adjustable, fully assembled **Swiss 7075 T6** specially hardcoated ball differential with carbide balls and carbide axial thrustbearing • fully adjustable front & rear suspension geometry: caster, camber, inboard/outboard toe, front dive, rear squat, ride height, downstops, track-width, roll center, wheelbase, Ackermann • pure racing design • available as US Foam-spec edition (#30 0007) and EU Rubber-spec edition (#30 0008)



World Championship Final #2 Winner, overall Third



**MICRO SIZE
HIGH COMPETITION**

**PREMIUM
LUXURY**

**HIGH
PREMIUM
PASSION
PERFORMANCE**

M18 PRO
1/18 LUXURY HIGH-COMPETITION 4WD RACING CAR

MICRO TOURING CAR-TYPE WHEEL MOUNTING SYSTEM

One of the most significant improvements on the M18 PRO is the **new wheel mounting system**. The new M18 PRO features micro versions of standard touring car hex wheel hubs, which mount directly to the efficient universal drive shafts. **New-style wheels** fit onto the hex wheel hub and are secured with machined lightweight nuts.

This system not only improves the performance of the car and allows for solid wheel mounting, it also makes wheel changes very quick and easy.

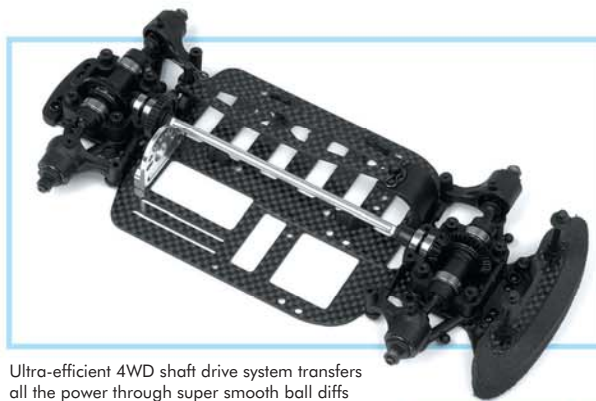

Ultra-efficient 4WD shaft drive system transfers all the power through super smooth ball diffs



Premium high-performance micro electronics available from XRAY will fit the M18 PRO perfectly

HIGH-PERFORMANCE PARTS



MULTI-FLEX™

XRAY **Multi-Flex Technology™ (MFT™)** now revolutionizes the micro platform in the new M18 PRO.

With the **MFT™** top deck you can set up and adjust the M18 PRO for all different racing conditions. No matter if you drive on asphalt or carpet, using rubber or foam tires, you can quickly, easily, and independently adjust MFT™ points on the top deck – front or rear – to give you different flex characteristics. Tailoring a micro car to the track has never been this easy!

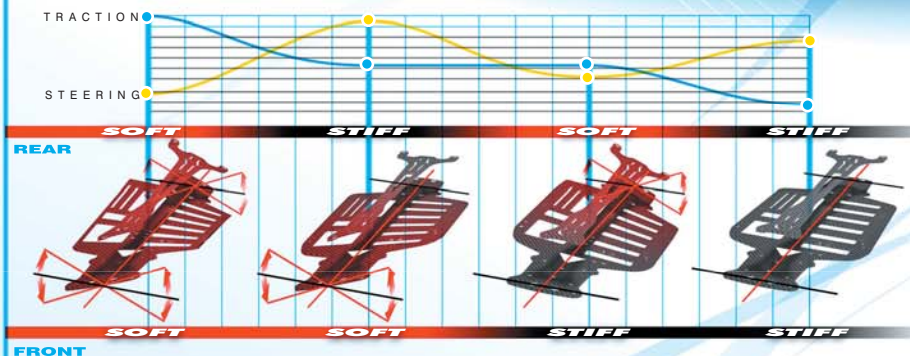

- new **high-competition** micro racing platform designed by legendary RC designer and XRAY's award-winning Chief Designer **Eng. Hudy Juraj**
- pure racing design & high-performance pedigree • designed for high-competition brushed and brushless micro motors • ultra-low center of gravity • 4WD shaft-drive ultra-efficient drivetrain • fully independent front and rear suspension • 6 cell in-line chassis CNC-machined from premium **1.6mm graphite** • revolutionary **XRAY Multi-Flex Technology™** top deck allows independent front/rear flex adjustment • new touring car-style hex hub wheels mounting system with aluminum wheel nuts • new harder arms for more aggressive and sharper handling • increased 6° caster for improved stability • externally-adjustable smooth ball differentials front and rear (factory pre-assembled) • adjustable downstops for precision setup • reinforced steering blocks and rear uprights to better withstand hard impacts • longer wheelbase for improved stability • decreased rear toe-in for **higher top speed** and sharper handling • premium **Swiss 7075 T6** aluminum universal adjustable motor holder • drivetrain includes 16 high-speed, high-quality ball-bearings for maximum efficiency and speed • ultra-true aluminum center drive shaft • graphite battery strap holds batteries securely in the chassis • battery stops ensure batteries will not move even in heavy crash • coil-over shocks for **precise chassis handling** • adjustable shock position for damping adjustment • adjustable body posts, front and rear • high-resilience lightweight front foam bumper and graphite bumper brace • spring-loaded servo saver protects steering servo • adjustable steering rod • **premium foam tires**: 50deg front, 35deg rear for maximum stability and easy handling • set of pinion gears for optimum gear ratio adjustment • both 36T and 42T spur gear included • lightweight high-performance racing body • adjustable turnbuckle set for toe-in adjustment included



XRAY Millennium RC Factory facts:

- operation started in 2007
- the largest RC manufacturing plant solely dedicated for luxury RC cars
- the facility is the size of a soccer stadium!
- the new facility includes everything necessary to design, develop, and produce the largest line of RC cars in-house
- production capacity of tens of thousands of RC parts per month
- dozens of the most modern German and Swiss CNC high-capacity, high-precision manufacturing machines
- more than 100 employees who are specially skilled and trained for RC car production

XRAY Millennium RC Factory features:

- large assembly line and packaging department to export products quickly
- extensive stock of all XRAY products guarantees 24-hour delivery with an astonishing 99% fill rate of available XRAY products
- the large factory is strategically divided into key sectors designed to make production clean and fast
- in-house R&D, marketing, sales, desktop publishing and accounting departments
- two indoor racetracks for prototype testing
- one of the largest asphalt indoor racetracks can be turned into a carpet indoor racetrack for electric car testing
- outdoor asphalt racetrack for testing and development
- outdoor off-road racetrack for off-road car testing and development

Large CNC milling department Unique, fully-automatic color-coating and hard-coating robot-operated line



Technology project was partially financially supported by European Union.



Exclusive world's largest asphalt indoor racetrack for instant prototype testing

XRAY

MILLENNIUM FACTORY

Highest-capacity German 11-axis CNC-cutting machines



All moulds are manufactured using state-of-the-art Swiss CNC mould-making machines



Composite parts are injected using precision German moulding machines



All precision parts are hand-ground on very precise grinding machines



Another CNC milling department



**RC RACING
ARENA**