

# XRAY BOBEE



MADE IN  
EUROPE

## INSTRUCTION MANUAL



[www.teamxray.com](http://www.teamxray.com)

## BEFORE YOU START

The XB8E is a high-competition, high-quality, 1/8 electric buggy intended for persons aged 16 years and older with previous experience building and operating RC model racing cars. This is not a toy; it is a precision racing model. This model racing car is not intended for use by beginners, inexperienced customers, or by children without direct supervision of a responsible, knowledgeable adult. If you do not fulfill these requirements, please return the kit in unused and unassembled form back to the shop where you have purchased it.

Before building and operating your XB8E, YOU MUST read through all of the operating instructions and instruction manual and fully understand them to get

## CUSTOMER SUPPORT

We have made every effort to make these instructions as easy to understand as possible. However, if you have any difficulties, problems, or questions, please do not hesitate to contact the XRAY support team at [info@teamxray.com](mailto:info@teamxray.com). Also, please visit our Web site at [www.teamxray.com](http://www.teamxray.com) to find the latest updates, set-up information, option parts, and many other goodies. We pride ourselves on taking excellent care of our customers.

You can join thousands of XRAY fans and enthusiasts in our online community at: [www.teamxray.com](http://www.teamxray.com)

**Failure to follow these instructions will be considered as abuse and/or neglect.**

## SAFETY PRECAUTIONS

Contains:

LEAD (CAS 7439-92-1) ANTIMONY (CAS 7440-36-0)

WARNING: This product contains a chemical known to the state of California to cause cancer and birth defects or other reproductive harm.

CAUTION: CANCER HAZARD

Contains lead, a listed carcinogen. Lead is harmful if ingested. Wash thoroughly after using. DO NOT use product while eating, drinking or using tobacco products. May cause chronic effects to gastrointestinal tract, CNS, kidneys, and blood. MAY CAUSE BIRTH DEFECTS.

When building, using and/or operating this model always wear protective glasses and gloves.

Take appropriate safety precautions prior to operating this model. You are responsible for this model's assembly and safe operation! Please read the instruction manual before building and operating this model and follow all safety precautions. Always keep the instruction manual at hand for quick reference, even after completing the assembly. Use only genuine and original authentic XRAY parts for maximum performance. Using any third party parts on this model will void guaranty immediately.

## IMPORTANT NOTES - GENERAL

- This product is not suitable for children under 16 years of age without the direct supervision of a responsible and knowledgeable adult.
- Carefully read all manufacturers warnings and cautions for any parts used in the construction and use of your model.
- Assemble this kit only in places away from the reach of very small children.
- First-time builders and users should seek advice from people who have building experience in order to assemble the model correctly and to allow the model to reach its performance potential.
- Exercise care when using tools and sharp instruments.
- Take care when building, as some parts may have sharp edges.
- Keep small parts out of reach of small children. Children must not be allowed to put any parts in their mouth, or pull vinyl bag over their head.
- Read and follow instructions supplied with paints and/or cement, if used (not included in kit).
- Immediately after using your model, do NOT touch equipment on the model such as the motor and speed controller, because they generate high temperatures. You may seriously burn yourself seriously touching them.
- Follow the operating instructions for the radio equipment at all times.
- Do not put fingers or any objects inside rotating and moving parts, as this may cause damage or serious injury as your finger, hair, clothes, etc. may get caught.
- Be sure that your operating frequency is clear before turning on or running your model, and never share the same frequency with somebody else at the same time. Ensure that others are aware of the operating frequency you are using and when you are using it.
- Use a transmitter designed for ground use with RC cars. Make sure that no one else is using the same frequency as yours in your operating area. Using the same frequency at the same time, whether it is driving, flying or sailing, can cause loss of control of the RC model, resulting in a serious accident.
- Always turn on your transmitter before you turn on the receiver in the car. Always turn off the receiver before turning your transmitter off.
- Keep the wheels of the model off the ground when checking the operation of the radio equipment.
- Disconnect the battery pack before storing your model.
- When learning to operate your model, go to an area that has no obstacles that can damage your model if your model suffers a collision.
- Remove any sand, mud, dirt, grass or water before putting your model away.
- If the model behaves strangely, immediately stop the model, check and clear the problem.
- To prevent any serious personal injury and/or damage to property, be responsible when operating all remote controlled models.
- The model car is not intended for use on public places and roads or areas where its operation can conflict with or disrupt pedestrian or vehicular traffic.
- Because the model car is controlled by radio, it is subject to radio interference from many sources that are beyond your control. Since radio interference can cause momentary loss of control, always allow a safety margin in all directions around the model in order to prevent collisions.
- Do not use your model:
  - Near real cars, animals, or people that are unaware that an RC car is being driven.
  - In places where children and people gather
  - In residential districts and parks
  - In limited indoor spaces
  - In wet conditions
  - In the street
  - In areas where loud noises can disturb others, such as hospitals and residential areas.
  - At night or anytime your line of sight to the model may be obstructed or impaired in any way.

the maximum enjoyment and prevent unnecessary damage. Read carefully and fully understand the instructions before beginning assembly.

Make sure you review this entire manual, download and use set-up book from the web, and examine all details carefully. If for some reason you decide the XB8E is not what you wanted or expected, do not continue any further. Your hobby dealer cannot accept your XB8E kit for return or exchange after it has been partially or fully assembled.

Contents of the box may differ from pictures. In line with our policy of continuous product development, the exact specifications of the kit may vary without prior notice.

### XRAY Europe

K Vystavisku 6992  
91101 Trenčín  
Slovakia, EUROPE  
Phone: 421-32-7401100  
Fax: 421-32-7401109  
E-mail: [info@teamxray.com](mailto:info@teamxray.com)

### XRAY USA

RC America, 2030 Century Center Blvd #15  
Irving, TX 75062  
USA  
Phone: (800) 519-7221 \* (214) 744-2400  
Fax: (214) 744-2401  
E-mail: [xray@rcamerica.com](mailto:xray@rcamerica.com)

Improper operation may cause personal and/or property damage. XRAY and its distributors have no control over damage resulting from shipping, improper construction, or improper usage. XRAY assumes and accepts no responsibility for personal and/or property damages resulting from the use of improper building materials, equipment and operations. By purchasing any item produced by XRAY, the buyer expressly warrants that he/she is in compliance with all applicable federal, state and local laws and regulation regarding the purchase, ownership and use of the item. The buyer expressly agrees to indemnify and hold harmless XRAY for all claims resulting directly or indirectly from the purchase, ownership or use of the product. By the act of assembling or operating this product, the user accepts all resulting liability. If the buyer is not prepared to accept this liability, then he/she should return this kit in new, unassembled, and unused condition to the place of purchase.

To prevent any serious personal injury and/or damage to property, please be responsible when operating all remote controlled models.



## IMPORTANT NOTES - ELECTRICAL

- Insulate any exposed electrical wiring (using heat shrink tubing or electrical tape) to prevent dangerous short circuits. Take maximum care in wiring, connecting and insulating cables. Make sure cables are always connected securely. Check connectors for if they become loose. And if so, reconnect them securely. Never use R/C models with damaged wires. A damaged wire is extremely dangerous, and can cause short-circuits resulting in fire. Please have wires repaired at your local hobby shop.
- Low battery power will result in loss of control. Loss of control can occur due to a weak battery in either the transmitter or the receiver. Weak running battery may also result in an out of control car if your car's receiver power is supplied by the running battery. Stop operation immediately if the car starts to slow down.
- When not using RC model, always disconnect and remove battery.
- Do not disassemble battery or cut battery cables. If the running battery short-circuits, approximately 300W of electricity can be discharged, leading to fire or burns. Never disassemble battery or cut battery cables.
- Use a recommended charger for the receiver and transmitter batteries and follow the instructions correctly. Over-charging, incorrect charging, or using inferior chargers can cause the batteries to become dangerously hot.

Recharge battery when necessary. Continual recharging may damage battery and, in the worst case, could build up heat leading to fire. If battery becomes extremely hot during recharging, please ask your local hobby shop for check and/or repair and/or replacement.

- Regularly check the charger for potential hazards such as damage to the cable, plug, casing or other defects. Ensure that any damage is rectified before using the charger again. Modifying the charger may cause short-circuit or overcharging leading to a serious accident. Therefore do not modify the charger.
- Always unplug charger when recharging is finished.
- Do not recharge battery while battery is still warm. After use, battery retains heat. Wait until it cools down before charging.
- Do not allow any metal part to short circuit the receiver batteries or other electrical/electronic device on the model.
- Immediately stop running if your RC model gets wet as may cause short circuit.
- Please dispose of batteries responsibly. Never put batteries into fire.

## R/C & BUILDING TIPS

- Make sure all fasteners are properly tightened. Check them periodically.
- Make sure that chassis screws do not protrude from the chassis.
- For the best performance, it is very important that great care is taken to ensure the free movement of all parts.
- Clean all ball-bearings so they move very easily and freely.
- Tap or pre-thread the plastic parts when threading screws.
- Self-tapping screws cut threads into the parts when being tightened. Do not use excessive force when tightening the self-tapping screws because you may strip out the thread in the plastic. We recommended you stop tightening a screw when you feel some resistance.
- Ask your local hobby shop for any advice.

Please support your local hobby shop. We at XRAY Model Racing Cars support all local hobby dealers. Therefore we ask you, if at all possible, to purchase XRAY products at your hobby dealer and give them your support like we do. If you have difficulty finding XRAY products, please check out [www.teamxray.com](http://www.teamxray.com) to get advice, or contact us via email at [info@teamxray.com](mailto:info@teamxray.com), or contact the XRAY distributor in your country.

## WARRANTY

XRAY guarantees this model kit to be free from defects in both material and workmanship within 30 days of purchase. The total monetary value under warranty will in no case exceed the cost of the original kit purchased. This warranty does not cover any components damaged by use or modification or as a result of wear. Part or parts missing from this kit must be reported within 30 days of purchase. No part or parts will be sent under warranty without proof of purchase. Should you find a defective or missing part, contact the local distributor. Service and customer support will be provided through local hobby store where you have purchased the kit, therefore make sure to purchase any XRAY products at your local hobby store. This model racing car is considered to be a high-performance racing vehicle. As such this vehicle will be used in an extreme range of conditions and situations, all which may cause premature wear or failure of any component. XRAY has no control over usage of vehicles once they leave the dealer, therefore XRAY can only offer warranty against all manufacturer's defects in materials, workmanship, and assembly at point of sale and before use. No warranties are expressed or implied that cover damage caused by what is considered normal use, or cover or imply how long any model cars' components or electronic components will last before requiring replacement.

Due to the high performance level of this model car you will need to periodically maintain and replace consumable components. Any and all warranty coverage will not cover replacement of any part or component damaged by neglect, abuse, or improper or unreasonable use. This includes but is not limited to

damage from crashing, chemical and/or water damage, excessive moisture, improper or no maintenance, or user modifications which compromise the integrity of components. Warranty will not cover components that are considered consumable on RC vehicles. XRAY does not pay nor refund shipping on any component sent to XRAY or its distributors for warranty. XRAY reserves the right to make the final determination of the warranty status of any component or part.

### Limitations of Liability

XRAY makes no other warranties expressed or implied. XRAY shall not be liable for any loss, injury or damages, whether direct, indirect, special, incidental, or consequential, arising from the use, misuse, or abuse of this product and/or any product or accessory required to operate this product. In no case shall XRAY's liability exceed the monetary value of this product.

**Take adequate safety precautions prior to operating this model. You are responsible for this model's assembly and safe operation.**

**Disregard of the any of the above cautions may lead to accidents, personal injury, or property damage. XRAY MODEL RACING CARS assumes no responsibility for any injury, damage, or misuse of this product during assembly or operation, nor any addictions that may arise from the use of this product.**

**All rights reserved.**

## QUALITY CERTIFICATE

XRAY MODEL RACING CARS uses only the highest quality materials, the best compounds for molded parts and the most sophisticated manufacturing processes of TQM (Total Quality Management). We guarantee that all parts of a newly-purchased kit are manufactured with the highest regard to quality. However, due to the many factors inherent in model racecar competition, we cannot guarantee

any parts once you start racing the car. Products which have been worn out, abused, neglected or improperly operated will not be covered under warranty.

We wish you enjoyment of this high-quality and high-performance RC car and wish you best success on the track!

**In line with our policy of continuous product development, the exact specifications of the kit may vary. In the unlikely event of any problems with your new kit, you should contact the model shop where you purchased it, quoting the part number.**

**We do reserve all rights to change any specification without prior notice. All rights reserved.**

# SYMBOLS USED

Part bags used 	Assemble in the specified order 	Assemble left and right sides the same way 	Assemble front and rear the same way 	Pay attention here 	Assemble as many times as specified (here twice) 	Apply instant glue 	Apply oil 	Apply grease 	Apply threadlock 
Cut off shaded portion 	Use special tool 	Cut off remaining material 	Time 	Use cleaner or WD-40 	Tighten screw gently 	Ensure smooth non-binding movement 	Use pliers 	Follow tip here 	Follow Set-Up Book 

# TOOLS REQUIRED

Phillips 5.0mm (HUDY TOOLS)		17mm Wheel Nut Tool (HUDY #107570)		Special Tool for all turnbuckles, nuts (HUDY #108090)		Cross Wrench (HUDY #107581)	
Allen 1.5 / 2.0 / 2.5 / 3.0mm (HUDY TOOLS)							
Ball Allen 2.5mm (HUDY TOOLS)							
Arm Reamer 3mm/4mm (HUDY TOOLS)							
Socket 5.0 / 5.5mm (HUDY TOOLS)							
Side Cutters (HUDY #189010)		Hobby Knife		Needle Nose Pliers (HUDY #189020)		Scissors (HUDY #188990)	
				Snap Ring Pliers (HUDY #189040)			Body Reamer (HUDY #107600) or (HUDY #107601)

# TOOLS & EQUIPMENT INCLUDED

Silicone Shock Oil 	Silicone Diff Oil 	Graphite Grease (HUDY #106210) 	 To ensure that you always have access to the most up-to-date version of the XRAY Set-up Book, XRAY will now be offering only the digital online version at our Web site at <a href="http://www.teamxray.com">www.teamxray.com</a> . By offering this online version instead of including a hardcopy printed version in kits, you will always be assured of having the most current updated version.
------------------------	-----------------------	------------------------------------	---

# EQUIPMENT REQUIRED

Transmitter 	Receiver 	Electric Motor 	Pinion Gear 	Speed Controller 	LiPo Battery 	Battery Charger 
Steering Servo 						
Bearing Oil 	Threadlock 	CA Glue 	Transmitter Batteries 	Tires & Wheels 	Lexan™ Paint 	

## TIP FRONT & REAR DIFF GEAR MESH ADJUSTMENT

Before filling in the differentials with oil we suggest that you first check gear mesh as below. If there is too much or too little diff side play, this may create non-optimal gear mesh between the diff gear and the pinion drive gear. This is easily resolved by inserting 1 or 2 of the included thin shims behind a diff outdrive ball-bearing, depending on how much play there is.

THE LOCATION OF THE SHIM(S) DEPENDS ON WHETHER YOU ARE TRYING TO CLOSE OR OPEN THE GAP:

### INCLUDED SHIM

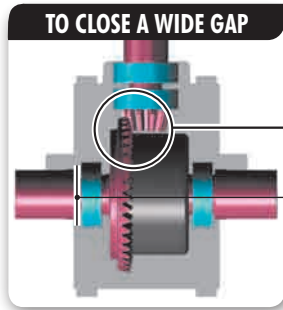

#### TO CLOSE A WIDE GAP

#### CLOSE A WIDE GAP



insert shim(s) here

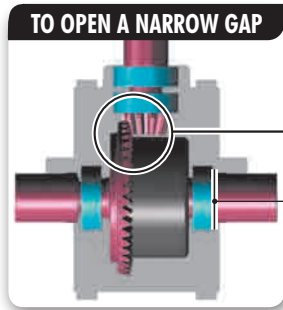

#### TO OPEN A NARROW GAP

#### OPEN A NARROW GAP



insert shim(s) here



To close a wide gap:  
add 1 or 2 shims against diff spur gear



#962080 WASHER S 8 x 0.1 mm (10)  
#962081 WASHER S 8 x 0.2 mm (10)



To open a narrow gap:  
add 1 or 2 shims on the other side of the diff, away from spur gear

### OPTION SHIM

For easier gear mesh adjustments, OPTION S13 x 0.2 shims are used. These shims can be placed behind the bearing which is quicker.

To close a wide gap:  
add 1 or 2 shims against diff spur gear

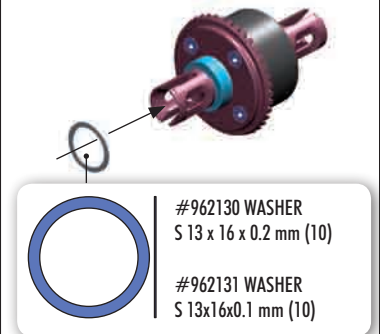

To open a narrow gap:  
add 1 or 2 shims on the other side of the diff, away from spur gear

## TIP DRIVE SHAFT PINS SERVICING

To enjoy the longest possible lifespan of the drive shafts and diff outdrives, it is extremely important to properly service the drive shaft pins. Inspect the pins after every 3 hours of run time. If the pins show any wear, replace them with new pins.



1 Do not use drive shafts when the pins are worn.

2 Press out the worn pins.

3 Press in new pins and regularly inspect for wear.



For easy drive pin replacement use #106000 HUDY Drive Pin Replacement Tool.



To replace the worn pins use only premium HUDY drive pins #106050.

## TIP GRAPHITE PARTS PROTECTION

Follow this tech tip to protect the graphite parts.

### Protect all XB8 Graphite Parts:

- Front shock tower
- Rear shock tower

### Fine sandpaper

Use fine sandpaper to sand smooth the edges of all graphite parts.



Apply CA glue to all edges of the graphite parts.



## TIP INSTALLING PIVOT BALLS INTO COMPOSITE BALL JOINTS



1 Place the pivot ball on the ball joint and use a screw to tighten it to an engine mount or some other part.



2 Tighten screw until pivot ball is tight against block.



3 Lift ball joint until it snaps into place over pivot ball. Ball joint should move freely.



4 The finished joint.



5 Loosen and remove screw.

# 1. FRONT & REAR DIFFERENTIALS

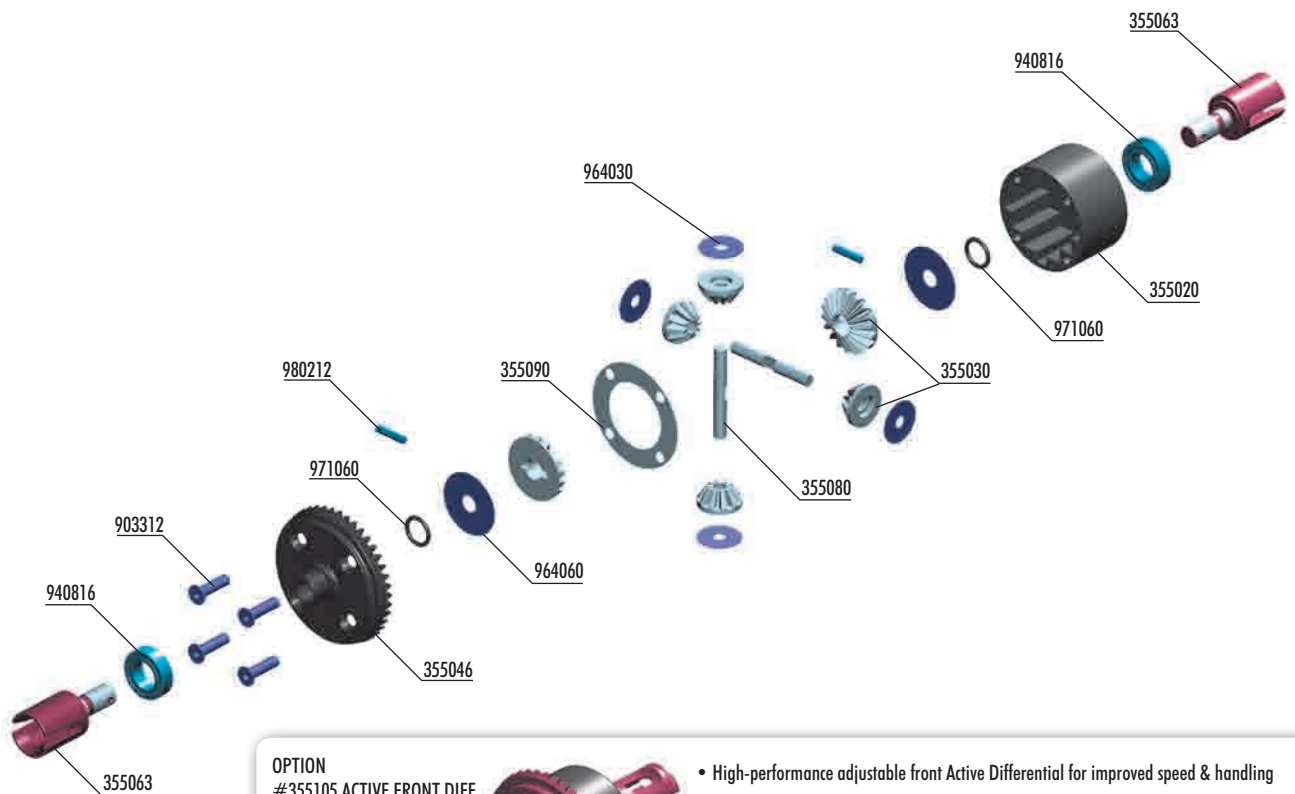

**OPTION**  
#355105 ACTIVE FRONT DIFF

- High-performance adjustable front Active Differential for improved speed & handling
- Fully adjustable on- and off-power performance using different internal segments and gears
- Improves diff action and increases traction
- Easy and consistent steering

<b>BAGS</b> <b>Oil</b> <b>2x</b>	35 5003	XB8 FRONT/REAR DIFFERENTIAL 46T - SET	90 3312	HEX SCREW SFH M3x12 (10)
	35 5020	DIFFERENTIAL CASE	94 0816	HIGH-SPEED BALL-BEARING 8x16x5 BLUE COVERED (2)
	35 5030	STEEL DIFF BEVEL & SATELLITE GEARS (2+4)	96 4030	WASHER S 3.5x12x0.2 (10)
	35 5046	FRONT/REAR DIFF LARGE BEVEL GEAR 46T - HUDY STEEL	96 4060	WASHER S 6x18x0.2 (10)
	35 5063	F/R DIFF OUTDRIVE ADAPTER - LIGHTW. - HUDY SPRING STEEL™ (2)	97 1060	SILICONE O-RING 6x1.5 (10)
	35 5080	DIFF PIN (2)	98 0212	PIN 2x11.6 (10)
	35 5090	DIFF GASKET (4)		



**2x** **F=R**

FRONT/REAR DIFF LARGE BEVEL GEAR	
#355038	DIFF LARGE BEVEL GEAR 38T (OPTION) *
#355040	DIFF LARGE BEVEL GEAR 40T (OPTION) *
#355046	DIFF LARGE BEVEL GEAR 46T (STANDARD)

\* These OPTIONAL bevel gears must be used with OPTIONAL #355110 bevel gear 12T

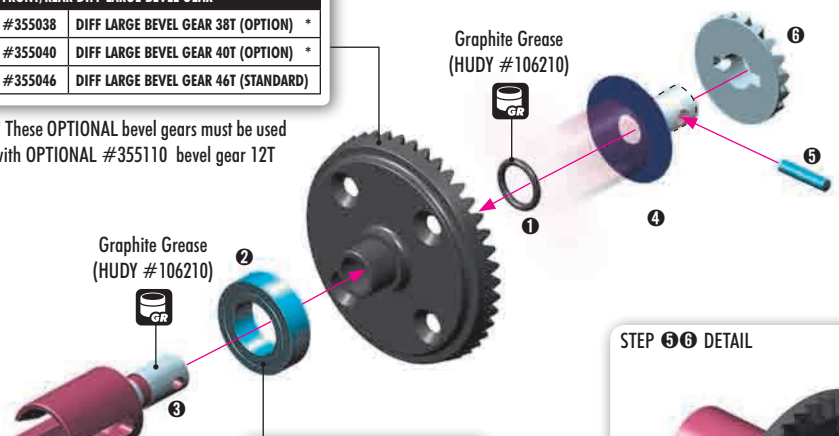



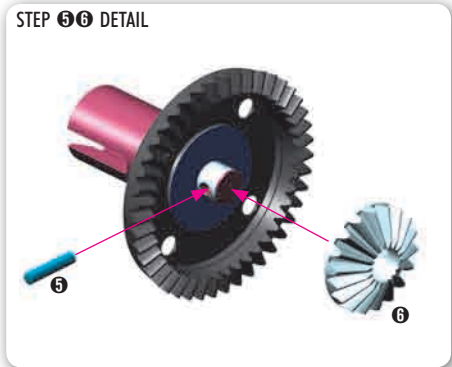

**TIP** Use HUDY Ball-Bearing Grease or Oil for servicing:

- #106220 - Standard
- #106221 - Extra
- #106222 - Premium
- #106230 - Bearing Oil



**SET-UP BOOK**  
DIFFERENTIAL GEARS

# FRONT & REAR DIFFERENTIALS

-  940816  
BB 8x16x5
-  964060  
S 6x18x0.2
-  971060  
O 6x1.5
-  980212  
P 2x11.6

**2x**

**F=R**

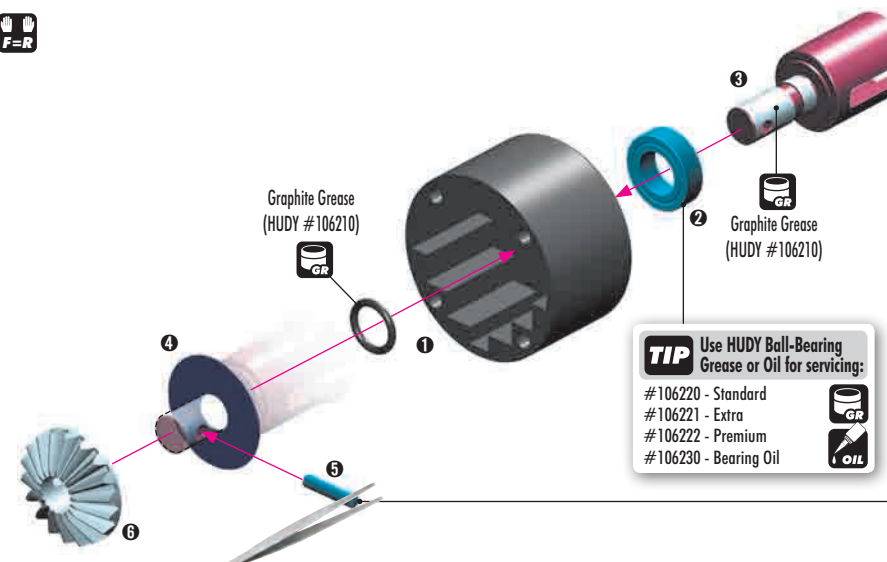

Graphite Grease (HUDY #106210)

Graphite Grease (HUDY #106210)

**TIP** Use HUDY Ball-Bearing Grease or Oil for servicing:

- #106220 - Standard
- #106221 - Extra
- #106222 - Premium
- #106230 - Bearing Oil

**STEP 6 DETAIL**



-  903312  
SFH M3x12
-  964030  
S 3.5x12x0.2

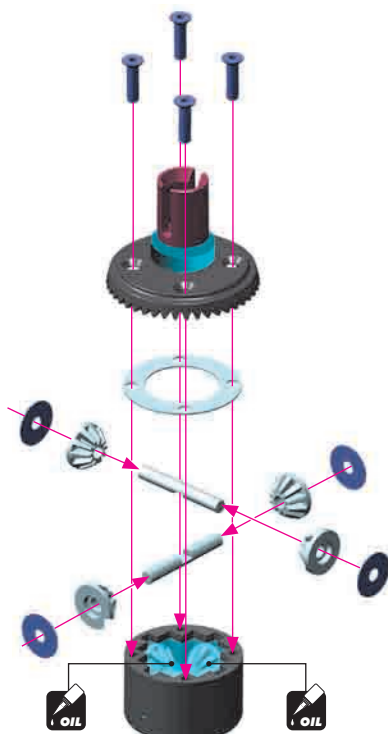

## VERY IMPORTANT!

Use these silicone oils included in the kit for initial settings:  
Front diff: 5000cSt / Rear diff: 2000cSt

**CORRECT** ✓



Fill the differentials with oil just above the satellite gears.

**INCORRECT** ✗



**! IMPORTANT!** Do not overfill the differential. If there is too much oil in the differential, it may leak after it cools down after use.

**To ensure you have the same amount of oil from rebuild to rebuild, do the following:**

#107865 HUDY Ultimate Digital Pocket Scale 300g ± 0.01g



40g



42.1g

**40g + 2.1g = 42.1g**

1. Put the diff (without oil) on the scale and check the weight (approximately 40g).
2. Slowly pour oil into the diff and watch the weight. Add 2.1g of oil into the diff. The approximate weight of the diff+oil is 42.1g.

**SET-UP BOOK**

DIFFERENTIAL OIL

**Front diff:**  
Silicone oil 5000cSt  
Fill just above the satellite gears.

**Rear diff:**  
Silicone oil 2 000cSt  
Fill just above the satellite gears.

Tighten the screws equally



Finish tightening in this order

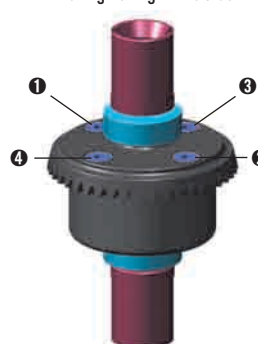

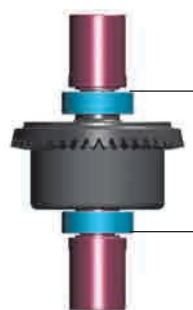

32.3~32.5 mm

After assembly the differentials should have a length of 32.3~32.5 mm measured from the ends of the installed ball-bearings. If differentials are longer, retighten the 4 screws holding the crown gears.

# CENTER DIFFERENTIAL

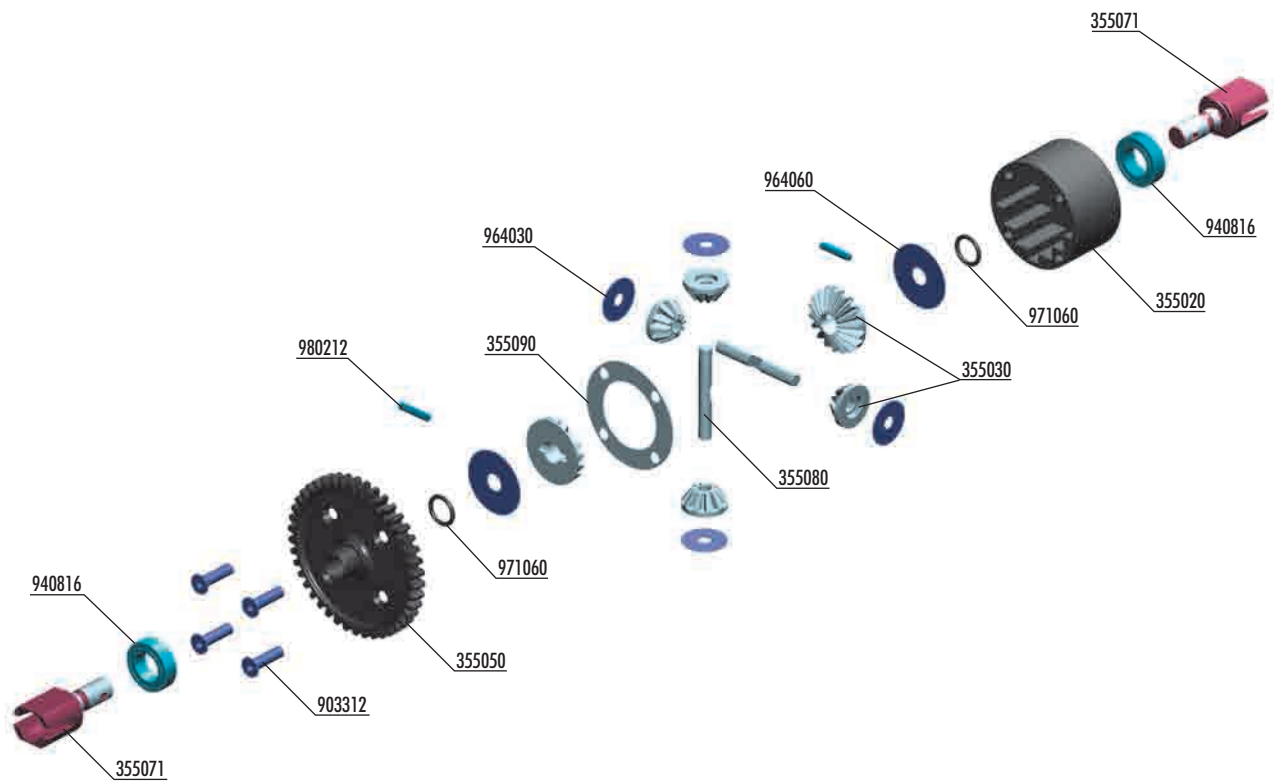

**BAG**

**01.3**

35 5012	CENTRAL DIFFERENTIAL - SET	90 3312	HEX SCREW SFH M3x12 (10)
35 5020	DIFFERENTIAL CASE	94 0816	HIGH-SPEED BALL-BEARING 8x16x5 BLUE COVERED (2)
35 5030	STEEL DIFF BEVEL & SATELLITE GEARS (2+4)	96 4030	WASHER S 3.5x12x0.2 (10)
35 5050	CENTER DIFF SPUR GEAR 46T	96 4060	WASHER S 6x18x0.2 (10)
35 5071	CENTER DIFF OUTDRIVE ADAPTER - LIGHTWEIGHT - HUDY STEEL (2)	97 1060	SILICONE O-RING 6x1.5 (10)
35 5080	DIFF PIN (2)	98 0212	PIN 2x11.6 (10)
35 5090	DIFF GASKET (4)		

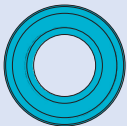

940816  
BB 8x16x5



964060  
S 6x18x0.2



971060  
O 6x1.5

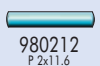

980212  
P 2x11.6

**SET-UP BOOK**

DIFFERENTIAL GEARS

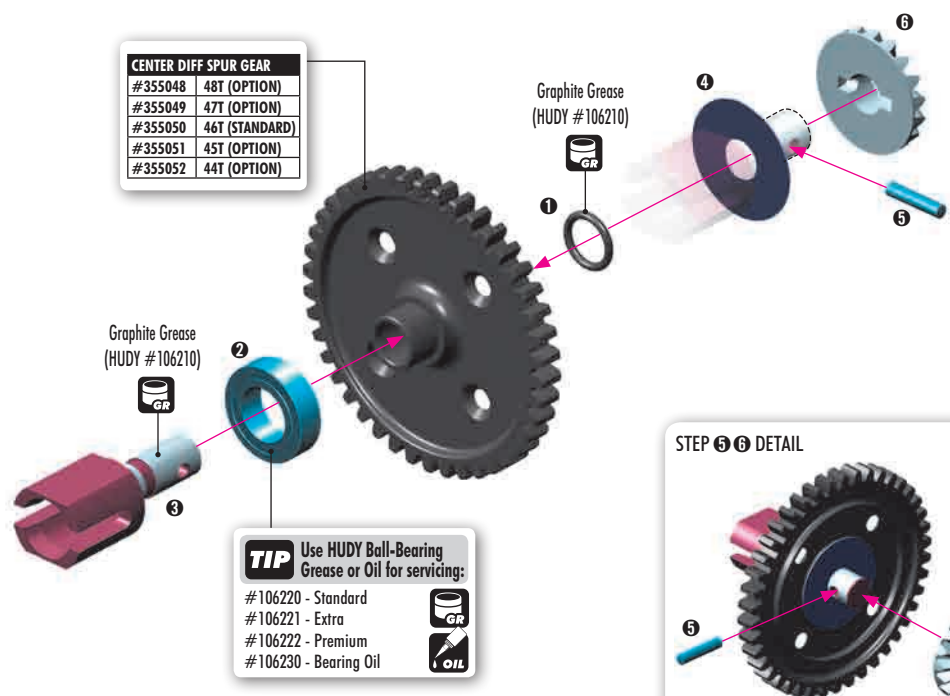



# CENTER DIFFERENTIAL



940816  
BB 8x16x5



964060  
S 6x18x0.2



971060  
O 6x1.5



980212  
P 2x11.6

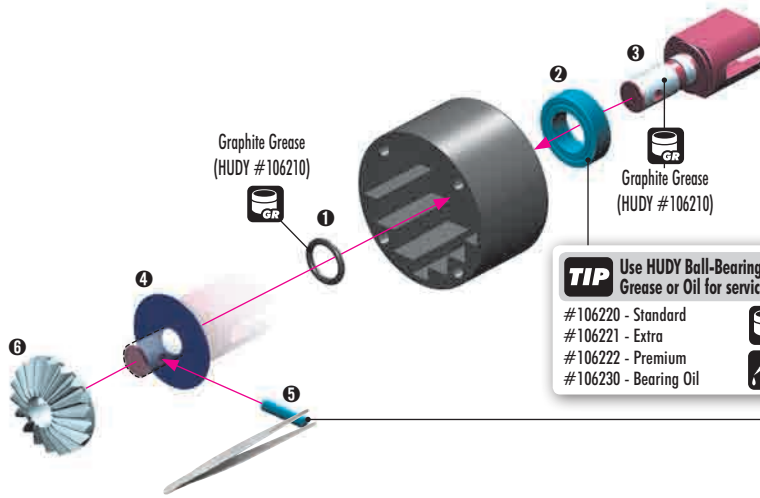

Graphite Grease  
(HUDY #106210)

Graphite Grease  
(HUDY #106210)

**TIP** Use HUDY Ball-Bearing Grease or Oil for servicing:

- #106220 - Standard
- #106221 - Extra
- #106222 - Premium
- #106230 - Bearing Oil

STEP 5 DETAIL

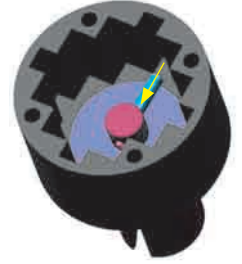

903312  
SFH M3x12



964030  
S 3.5x12x0.2

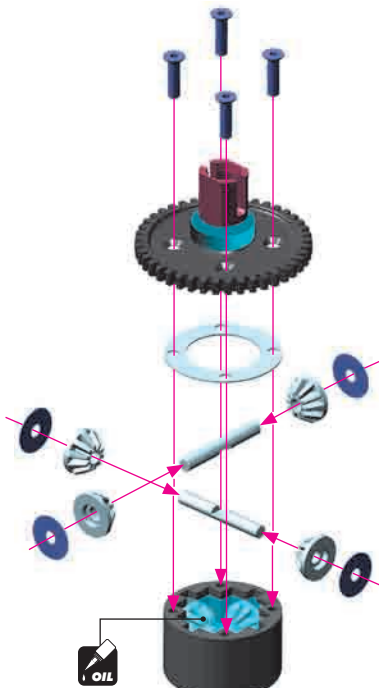

**Center diff:**

Silicone oil **5000cSt**

Fill to just above the satellite gears.

## VERY IMPORTANT!

Use the following silicone oil included in the kit for initial setting:

Center diff: **5000cSt**

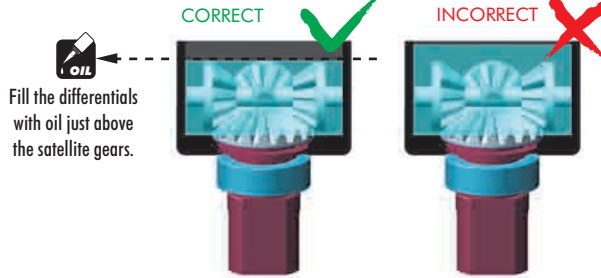

Fill the differentials with oil just above the satellite gears.

**IMPORTANT!**

Do not overfill the differential. If there is too much oil in the differential, it may leak after it cools down after use.

To ensure you have the same amount of oil from rebuild to rebuild, do the following:

#107865 HUDY Ultimate Digital Pocket Scale 300g ± 0.01g



1. Put the diff (without oil) on the scale and check the weight (approximately 40g).

2. Slowly pour oil into the diff and watch the weight. Add 2.1g of oil into the diff. The approximate weight of the diff + oil is 42.1g.

**SET-UP BOOK**

DIFFERENTIAL OIL

Tighten the screws equally



Finish tightening in this order

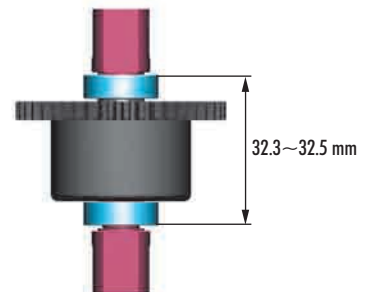
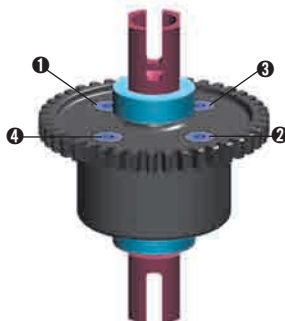

After assembly the differential should have a length of 32.3~32.5 mm measured from the ends of the installed ball-bearings. If differential is longer, retighten the 4 screws holding the spur gear.

# 2. FRONT TRANSMISSION

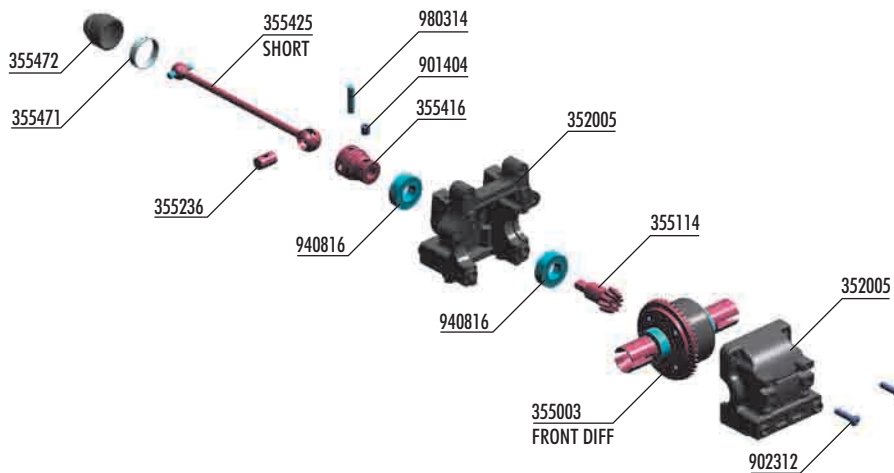

**BAG**

**02**

35 2005	XBB DIFF BULKHEAD BLOCK SET FRONT/REAR	35 5472	DRIVE SHAFT BOOT (2)
35 5003	XBB FRONT/REAR DIFFERENTIAL 46T - SET	90 1404	HEX SCREW SB M4x4 (10)
35 5114	BEVEL DRIVE GEAR 14T	90 2312	HEX SCREW SH M3x12 (10)
35 5236	CVD DRIVE SHAFT COUPLING - HUDY SPRING STEEL™	94 0816	HIGH-SPEED BALL-BEARING 8x16x5 RUBBER SEALED (2)
35 5416	CENTRAL CVD SHAFT UNIVERSAL JOINT - HUDY SPRING STEEL™	98 0314	PIN 3x14 (10)
35 5425	FRONT CENTRAL CVD DRIVE SHAFT - HUDY SPRING STEEL™		
35 5471	DRIVE SHAFT LOCKING RING (2)		



901404  
SB 4x4

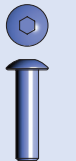

902312  
SH 3x12

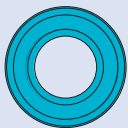

940816  
BB 8x16x5



980314  
P 3x14

**step 1**

**!** SHORT CVD DRIVE SHAFT

**TIP** Follow the TECH TIP on page 5 for drive shaft pin servicing

Graphite Grease (HUDY #106210)

The ring can be assembled by hand but for easy disassembling, we recommend using snap ring pliers (HUDY #189040)

**NOTE ORIENTATION** **!**

**TIP** ASSEMBLED VIEW

**STEP 1 DETAIL**

**BEFORE** inserting the clip on the central CVD shaft joint, apply a small amount of threadlock on the area where the clip goes.

**AFTER** inserting the clip on the central CVD shaft joint, turn the clip so that the slot is 90° from the pin. This will prevent the pin from opening the clip.

**step 2**

Push joint against gear to remove gap. Tighten set screw onto gear flat spot.

**STEP 5 DETAIL**

**TIP** Use HUDY Ball-Bearing Grease or Oil for servicing:  
 #106220 - Standard  
 #106221 - Extra  
 #106222 - Premium  
 #106230 - Bearing Oil

## step 3

**TIP** Follow the TECH TIP on page 5 to properly adjust the gear mesh.

**DETAIL** Cut on both front and rear bulkhead blocks

**!** FRONT DIFF 5000 cSt

Graphite Grease (HUDY #106210)

# REAR TRANSMISSION

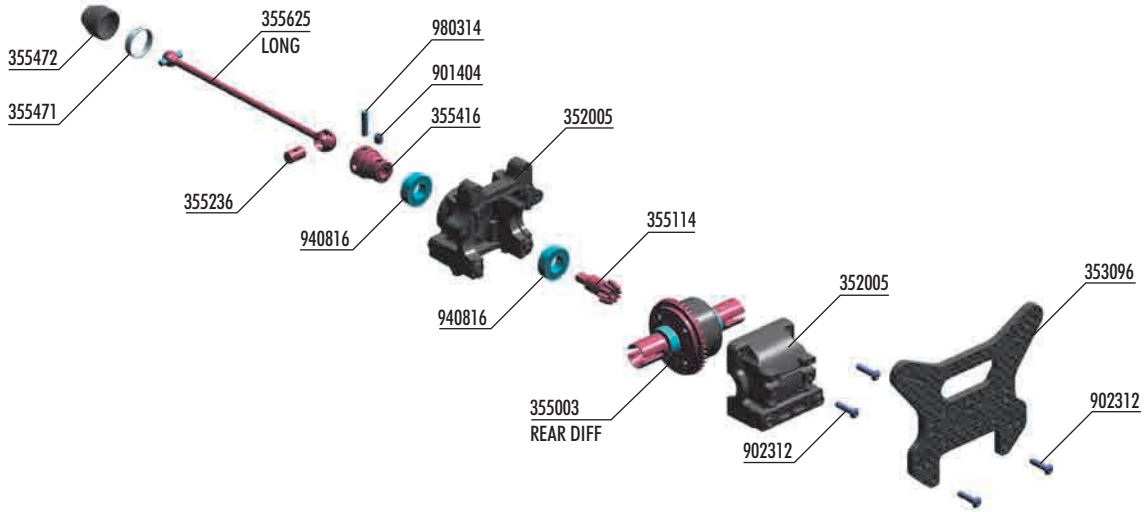

**BAG**

**02**

35 2005 X88 DIFF BULKHEAD BLOCK SET FRONT/REAR  
 35 5003 X88 FRONT/REAR DIFFERENTIAL 46T - SET  
 35 3096 X88 GRAPHITE REAR SHOCK TOWER - CNC MACHINED 3.5MM  
 35 5114 BEVEL DRIVE GEAR 14T  
 35 5236 CVD DRIVE SHAFT COUPLING - HUDY SPRING STEEL™  
 35 5416 CENTRAL CVD SHAFT UNIVERSAL JOINT - HUDY SPRING STEEL™  
 35 5625 REAR CENTRAL CVD DRIVE SHAFT - HUDY SPRING STEEL™

35 5471 DRIVE SHAFT LOCKING RING (2)  
 35 5472 DRIVE SHAFT BOOT (2)  
 90 1404 HEX SCREW SB M4x4 (10)  
 90 2312 HEX SCREW SH M3x12 (10)  
 94 0816 HIGH-SPEED BALL-BEARING 8x16x5 RUBBER SEALED (2)  
 98 0314 PIN 3x14 (10)



**step 1**

**LONG CVD DRIVE SHAFT**

**TIP** Follow the TECH TIP on page 5 for drive shaft pin servicing

Graphite Grease (HUDY #106210)

The ring can be assembled by hand but for easy disassembling, we recommend using snap ring pliers (HUDY #189040)

**NOTE ORIENTATION**

**TIP** ASSEMBLED VIEW

**STEP 4 DETAIL**

**PIN**

**BEFORE** inserting the clip on the central CVD shaft joint, apply a small amount of threadlock on the area where the clip goes.

**AFTER** inserting the clip on the central CVD shaft joint, turn the clip so that the slot is 90° from the pin. This will prevent the pin from opening the clip.

**step 3**

**DETAIL** Cut on both front and rear bulkhead blocks

**TIP** Follow the TECH TIP on page 5 to properly adjust the gear mesh.

**REAR DIFF 2000 cSt**

Graphite Grease (HUDY #106210)

**step 2**

Push joint against gear to remove gap. Tighten set screw onto gear flat spot.

**STEP 5 DETAIL**

**TIP** Use HUDY Ball-Bearing Grease or Oil for servicing:  
 #106220 - Standard  
 #106221 - Extra  
 #106222 - Premium  
 #106230 - Bearing Oil

**step 4**

Follow the TECH TIP on page 5 to protect graphite parts

**TIP**

**NOTE ORIENTATION**

### 3. REAR SUSPENSION

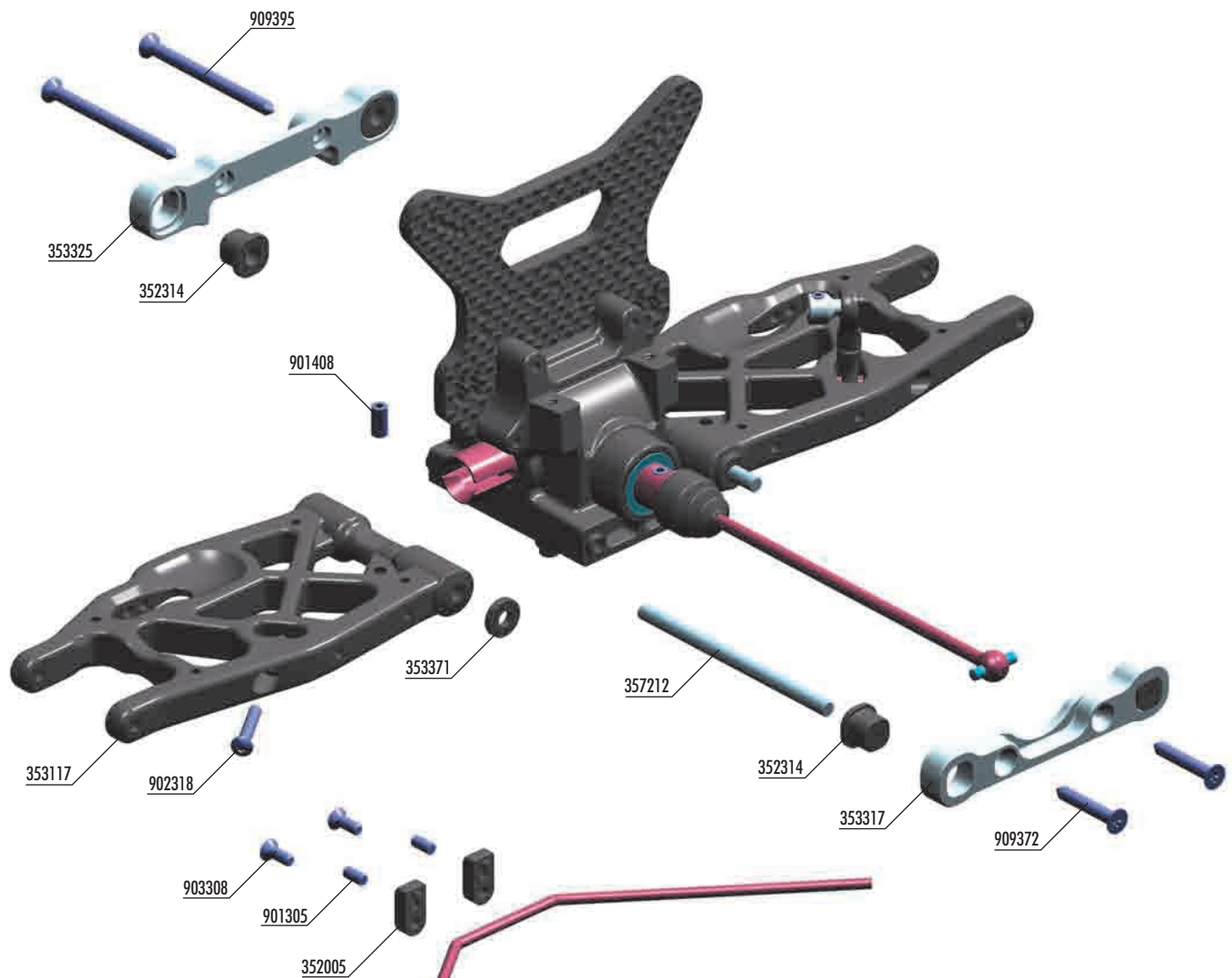

REAR ANTI-ROLL BARS	
#353422	2.2mm (OPTION)
#353424	2.4mm (OPTION)
#353426	2.6mm (STANDARD)
#353428	2.8mm (OPTION)
#353430	3.0mm (OPTION)
#353432	3.2mm (OPTION)

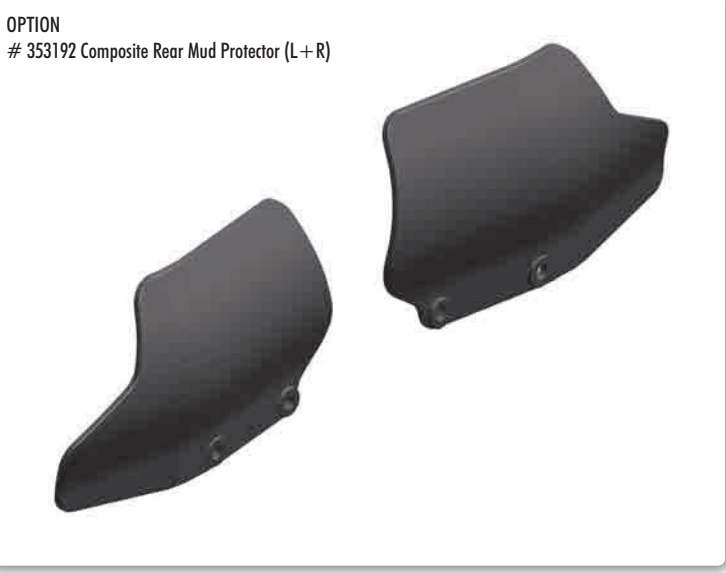

OPTION  
# 353192 Composite Rear Mud Protector (L+R)



- 33 3450 ANTI-ROLL BAR BALL JOINT 5.8 MM (2)
- 35 2005 XBB DIFF BULKHEAD BLOCK SET FRONT/REAR
- 35 2314 COMPOSITE ECCENTRIC BUSHINGS - V2 (2)
- 35 2460 PIVOT BALL 5.8 (10)
- 35 2470 BALL JOINT 5.8 (8)
- 35 3117 XBB COMPOSITE REAR LOWER SUSPENSION ARM
- 35 3192 XBB COMPOSITE REAR MUD PROTECTOR (L+R)
- 35 3317 XBB ALU REAR LOWER SUSP. HOLDER - FRONT - SQUARE ADJ. ROLL-CENTER
- 35 3325 XBB ALU REAR LOWER SUSP. HOLDER - REAR - SQUARE ADJ. ROLL-CENTER
- 35 3371 SET OF COMPOSITE LOWER ARM SHIMS
- 35 3426 REAR ANTI-ROLL BAR 2.6MM

- 35 7212 LOWER INNER PIVOT PIN F+R (2)
- 90 1303 HEX SCREW SB M3x3 (10)
- 90 1305 HEX SCREW SB M3x5 (10)
- 90 1312 HEX SCREW SB M3x12 (10)
- 90 1408 HEX SCREW SB M4x8 (10)
- 90 2318 HEX SCREW SH M3x18 (10)
- 90 3308 HEX SCREW SFH M3x8 (10)
- 90 9372 SCREW PHILLIPS SS 3.5x22 (10)
- 90 9395 SCREW PHILLIPS SS 3.5x45 (10)



909395  
SS 3.5x45

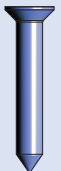

909372  
SS 3.5x22



901408  
SB M4x8



353371  
SHIM 4x10x2

## SET-UP BOOK

TOE-IN  
ANTI-SQUAT  
ROLL CENTER  
DOWNSTOP  
TRACK-WIDTH

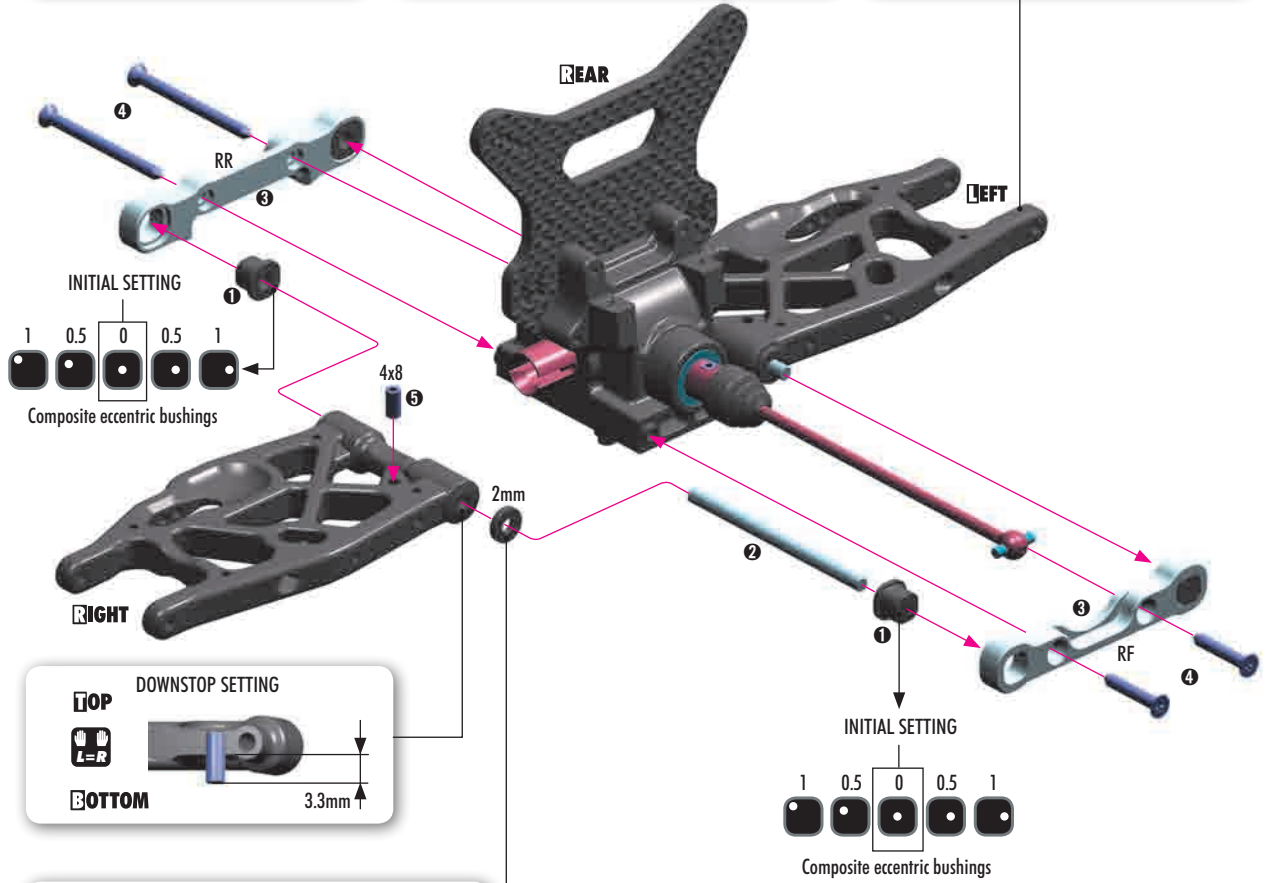
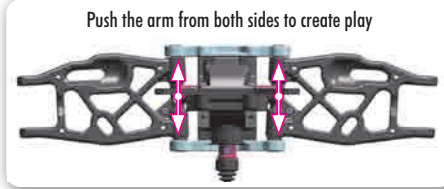
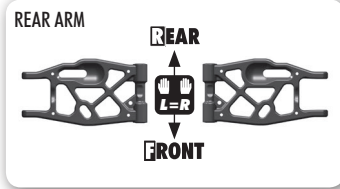

**TIP** If the suspension arm does not move freely use a HUDY Arm Reamer to resize the holes of the arms. (HUDY #107634)

All possible mounting alternatives of eccentric bushings

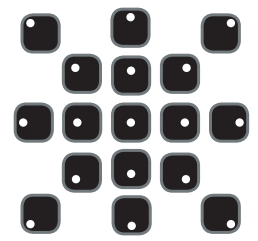

ECCENTRIC BUSHINGS HAVE TWO DIFFERENT OFFSETS FROM THE CENTER.

- Middle position = 0.5 mm or 0.5° from center
- Outer position = 1 mm or 1° from center

The new XRAY rear alu lower suspension holders provide even greater range of adjustment for the rear suspension. Using different combinations of eccentric bushings, fine adjustment of rear anti-squat, rear toe-in, rear roll center, and rear track-width can be obtained. For more information about the influence of rear anti-squat, rear toe-in, rear roll center and rear track width on car handling, please refer to HUDY Off-Road Set-up Book (#209099).

ANTI-SQUAT		
RR	RF	(°)
		=3°
		=4°
		=2°
		=4°
		=3°
		=5°
		=2°
		=3°
		=1°

ROLL CENTER		
RR	RF	(mm)
		=0mm
		=1mm
		=-1mm

The tables describe the amounts of rear anti-squat, rear toe-in, rear track-width change depending on the combinations of eccentric bushings used with 0 and 1mm, 1° off set. The 0.5mm, 0.5° represent the half change.

Example: 0(RR) - 0 (RF) = 3° = 3°  
 0(RR) - 0.5 (RF) = 3.5° = 3.5°  
 0(RR) - 1 (RF) = 4° = 4°

TRACK-WIDTH		
RR	RF	(mm)
		=308
		=306
		=310

TOE-IN		
RR	RF	(°)
		=3°
		=4°
		=2°
		=2°
		=3°
		=1°
		=4°
		=5°
		=3°

# REAR SUSPENSION



901312  
SB M3x12

2x  
L-R

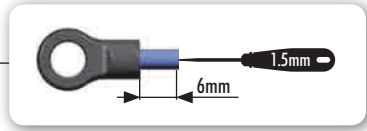
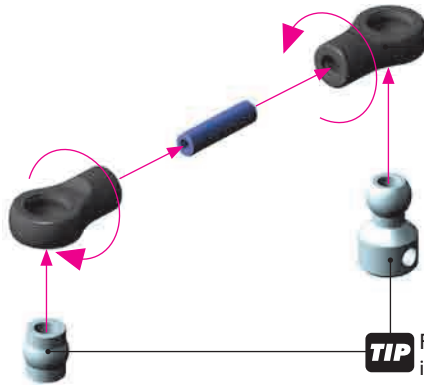

**TIP** Follow the TECH TIP on page 5 to install the pivot balls



901303  
SB M3x3



901305  
SB M3x5



902318  
SH M3x18



903308  
SFH M3x8

L-R

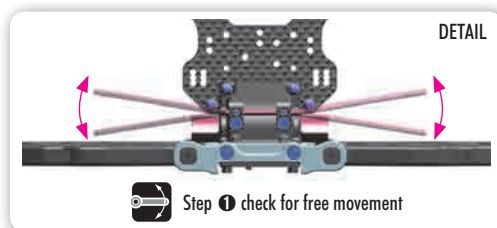
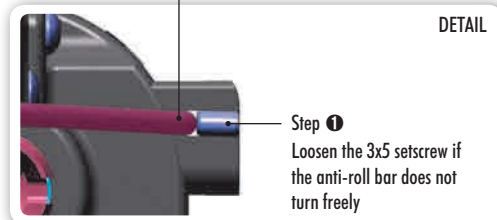
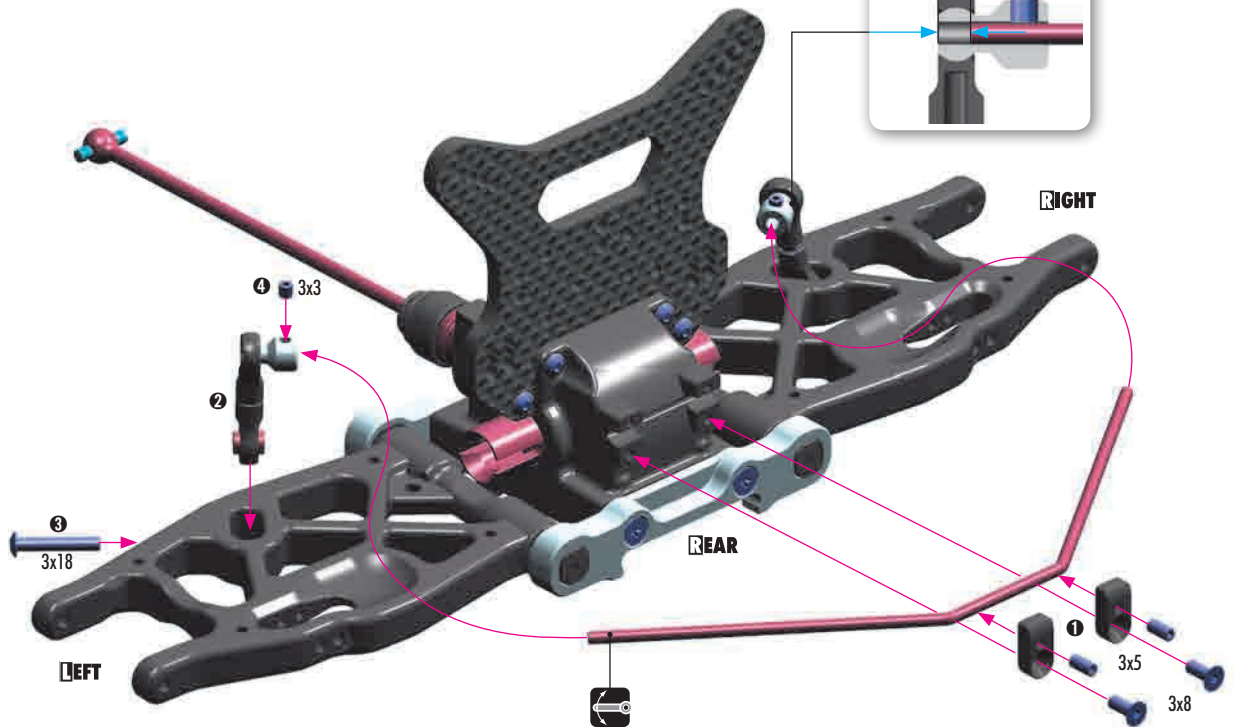

**SET-UP BOOK**

ANTI-ROLL BAR

# 4. REAR SUSPENSION

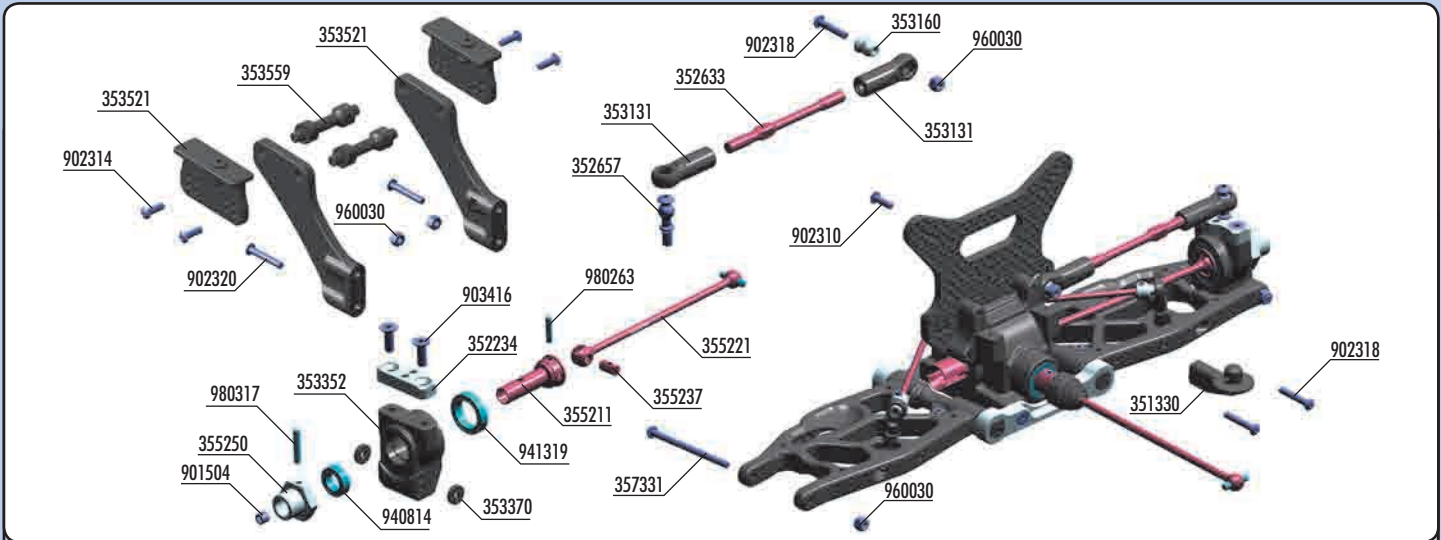

**BAG**

**04**

- |         |   |         |  |         |                 |
|---------|---|---------|--|---------|-----------------|
| 35 1330 | COMPOSITE REAR BODY POST - LONG                       | 35 5237 | CVD DRIVE SHAFT COUPLING - HUDY SPRING STEEL™    | 98 0263 | PIN 2.5x13 (10) |
| 35 2234 | XB8 ALU REAR HUB MOUNTING PLATE - SWISS 7075 T6       | 35 5250 | ALU WHEEL AXLE - BLACK COATED (2)                | 98 0317 | PIN 3x17 (10)   |
| 35 2633 | ADJ. TURNBUCKLE M5 L/R 72 MM - HUDY SPRING STEEL™ (2) | 35 7331 | XB808 REAR LOWER OUTER PIVOT PIN SCREW 3MM (2)   |         |                 |
| 35 2657 | BALL STUD 6.8MM WITH BACKSTOP L=8MM - M4x6 (2)        | 90 1504 | HEX SCREW SB M5x4 (10)                           |         |                 |
| 35 3131 | REAR UPPER INNER CAMBER LINK BALL JOINT - V3 (2)      | 90 2310 | HEX SCREW SH M3x10 (10)                          |         |                 |
| 35 3160 | MOUNTING BALL 6.8 (4)                                 | 90 2314 | HEX SCREW SH M3x14 (10)                          |         |                 |
| 35 3352 | XB8 COMPOSITE REAR UPRIGHT                            | 90 2318 | HEX SCREW SH M3x18 (10)                          |         |                 |
| 35 3370 | SET OF COMPOSITE REAR HUB CARRIER SHIMS               | 90 2320 | HEX SCREW SH M3x20 (10)                          |         |                 |
| 35 3521 | REAR WING POSTS                                       | 90 3416 | HEX SCREW SFH M4x16 (10)                         |         |                 |
| 35 3559 | COMPOSITE REAR WING MOUNT BRACE (2)                   | 94 0814 | HIGH-SPEED BALL-BEARING 8x14x4 BLUE COVERED (2)  |         |                 |
| 35 5211 | CVD DRIVE AXLE - HUDY SPRING STEEL™                   | 94 1319 | HIGH-SPEED BALL-BEARING 13x19x4 BLUE COVERED (2) |         |                 |
| 35 5221 | CVD UNIVERSAL DRIVE SHAFT - HUDY SPRING STEEL™        | 96 0030 | NUT M3 (10)                                      |         |                 |

- 901504  
SB M5x4
- 941319  
BB 13x19x4
- 940814  
BB 8x14x4
- 980317  
P 3x17
- 980263  
P 2.5x13
- 960030  
N M3
- 903416  
SFH M4x16
- 353370  
SHIM 3x9x2

**2x** **L=R**

**TIP** To tighten the setscrew you can also use the HUDY 17mm Wheel Nut Tool #107570

2.5mm

OFFSET WHEEL AXLES	
#355250	0mm (STANDARD)
#355251	+1mm (OPTION)
#355252	+2mm (OPTION)

**INITIAL SETTING**

**TIP** Follow the TECH TIP on page 5 for drive shaft pin servicing

Graphite Grease (HUDY #106210)

**TIP** Use HUDY Ball-Bearing Grease or Oil for servicing:

- #106220 - Standard
- #106221 - Extra
- #106222 - Premium
- #106230 - Bearing Oil

**ASSEMBLED VIEW**

**TIP** Ensure that the rear upright moves freely. If it does not move freely, use sandpaper to thin both wheelbase adjustment shims.

Shims for wheelbase adjustment

2mm

2mm

**RIGHT** **LEFT**

Do not overtighten the self-locking nut. Overtightening may result in suspension binding.

**TIP** **L=R** **ARM REAMER** (HUDY #107633)

If the rear upright does not move freely, use a HUDY Arm Reamer to resize the hole.

**Check for free movement**

**INITIAL SETTING**

# REAR SUSPENSION

## SET-UP BOOK

### CAMBER

**TIP** Follow the TECH TIP on page 5 to install the pivot balls

**TIP** Follow the TECH TIP on page 5 to install the pivot balls

**LEFT THREAD** **RIGHT THREAD**

**NOTE ORIENTATION**

**DETAIL**  
Use tools to tighten as shown  
Special Tool for all turnbuckles & nuts (HUDY #108090)

**Left thread** **RIGHT** **Right thread** **Right thread** **LEFT** **Left thread**

47.3 mm

## SET-UP BOOK

### ROLL CENTER

- 902318 SH M3x18
- 960030 N M3
- 353380 SHIM 4x7.5x1
- 353381 SHIM 4x7.5x2

**REAR** **NOTE ORIENTATION** **NOTE ORIENTATION** **LEFT** **RIGHT**

**OPTION** shims from the Last Aid Bag can be used for roll center adjustment.  
#353380 - Alu shim 4x7.5x1mm  
#353381 - Alu shim 4x7.5x2mm

**INITIAL POSITIONS** **L=R**

**INITIAL POSITIONS** **L=R**

- 902314 SH M3x14
- 902310 SH M3x10
- 960030 N M3
- 902318 SH M3x18
- 902320 SH M3x20

**TIP** For stiffer wing mounting use **OPTIONAL** alu wing mount brace #353550.

**INITIAL POSITIONS** **L=R**

R4 R3 F4 F3  
R2 R1 F2 F1

**Single Body Post INITIAL SETTING**

3x18 3x18 3x10 3x20

**REAR**

**Double Body Posts OPTION SETTING**

## SET-UP BOOK

### REAR WING



# 5. FRONT SUSPENSION

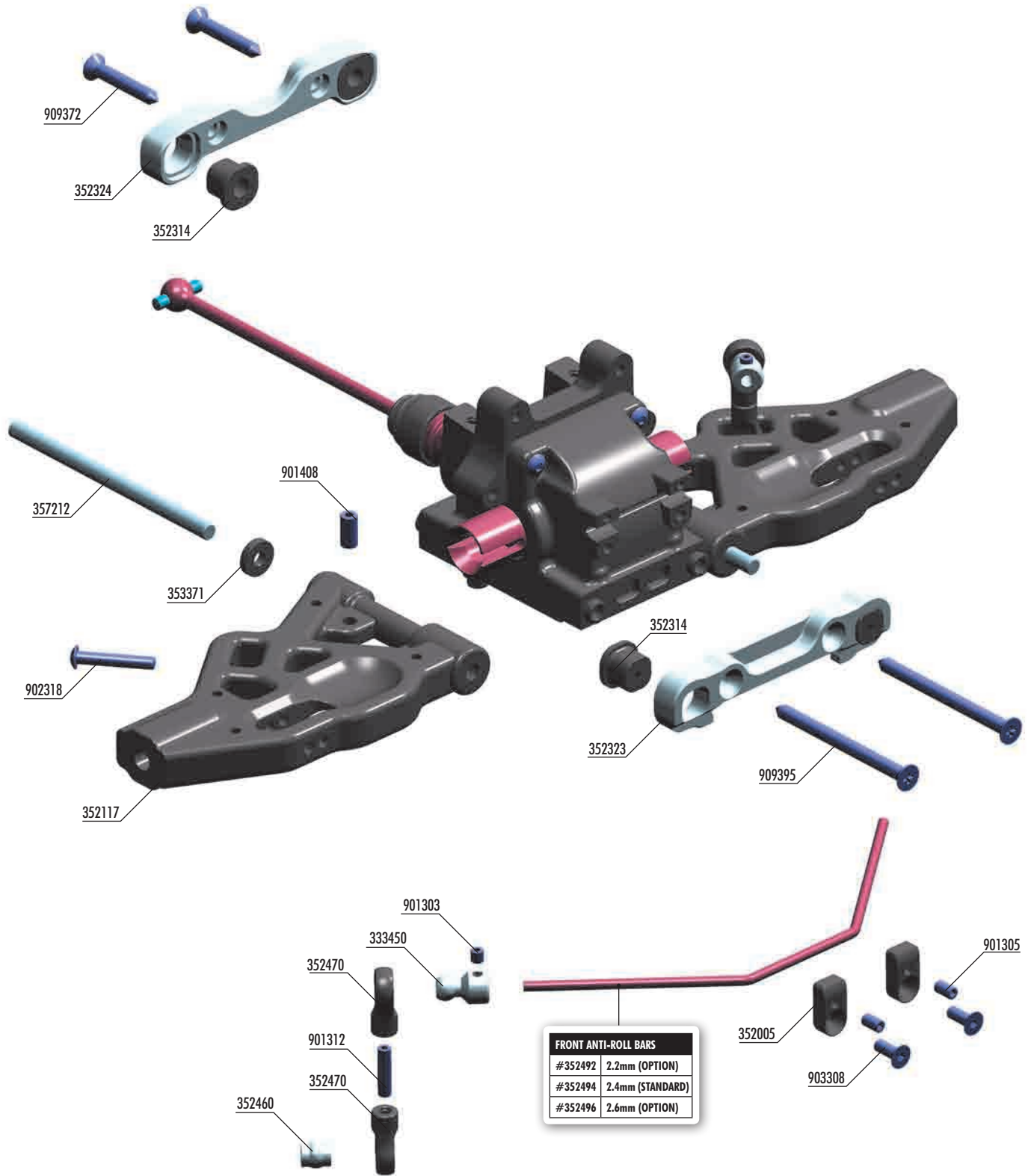

**BAG**

**05**

- |         |   |         |                               |
|---------|---|---------|-------------------------------|
| 33 3450 | ANTI-ROLL BAR BALL JOINT 5.8 MM (2)                                 | 35 7212 | LOWER INNER PIVOT PIN F+R (2) |
| 35 2005 | DIFF BULKHEAD BLOCK SET FRONT/REAR                                  | 90 1303 | HEX SCREW SB M3x3 (10)        |
| 35 2117 | XB8 COMPOSITE FRONT LOWER SUSPENSION ARM                            | 90 1305 | HEX SCREW SB M3x5 (10)        |
| 35 2117 | XB8 COMPOSITE FRONT LOWER SUSPENSION ARM                            | 90 1312 | HEX SCREW SB M3x12 (10)       |
| 35 2323 | ALU FRONT LOWER SUSP. HOLDER - FRONT - SQUARE ADJ. ROLL-CENTER - V2 | 90 1408 | HEX SCREW SB M4x8 (10)        |
| 35 2324 | ALU FRONT LOWER SUSP. HOLDER - REAR - SQUARE ADJ. ROLL-CENTER - V2  | 90 2318 | HEX SCREW SH M3x18 (10)       |
| 35 2314 | COMPOSITE SQUARE ADJ. ROLL-CENTER BUSHINGS - V2 (2)                 | 90 3308 | HEX SCREW SFH M3x8 (10)       |
| 35 2314 | COMPOSITE SQUARE ADJ. ROLL-CENTER BUSHINGS - V2 (2)                 | 90 9372 | SCREW PHILLIPS SS 3.5x22 (10) |
| 35 2460 | PIVOT BALL 5.8 (10)   | 90 9395 | SCREW PHILLIPS SS 3.5x45 (10) |
| 35 2470 | BALL JOINT 5.8 (8)  |         |                               |
| 35 2494 | FRONT ANTI-ROLL BAR 2.4MM   |         |                               |
| 35 3371 | SET OF COMPOSITE LOWER ARM SHIMS                                    |         |                               |

# FRONT SUSPENSION



353371  
SHIM 4x10x2



909395  
SS 3.5x45



909372  
SS 3.5x22



901408  
SB M4x8

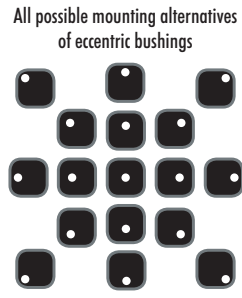
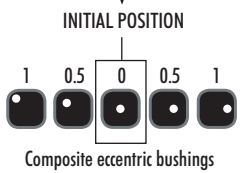
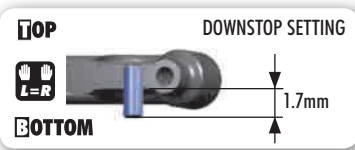
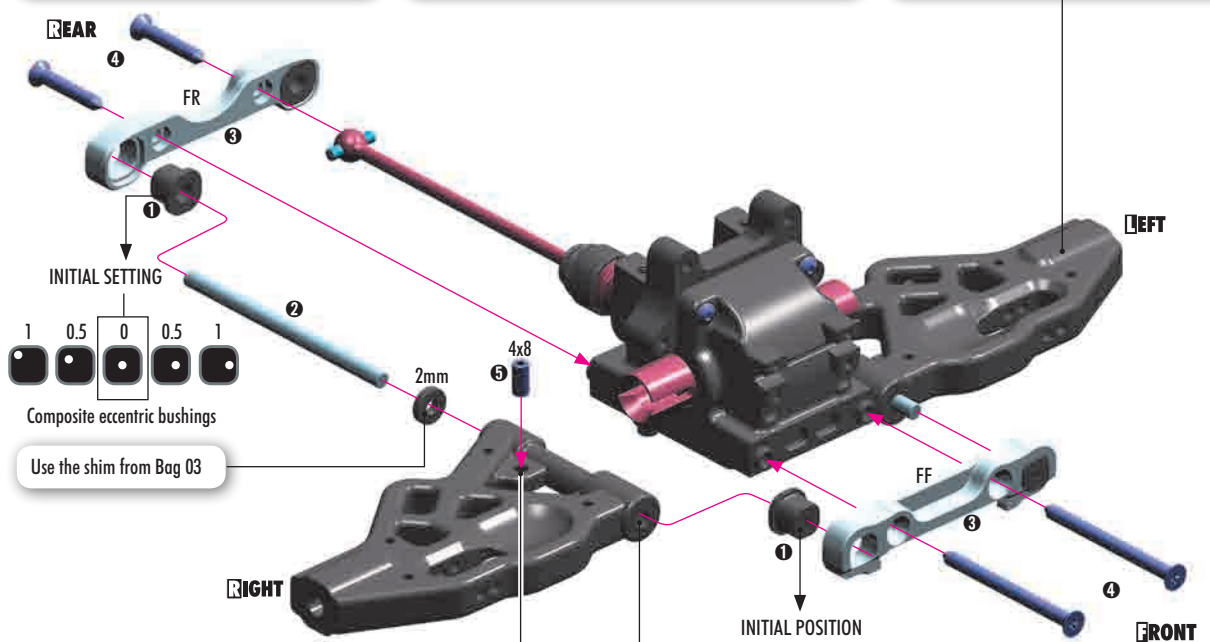
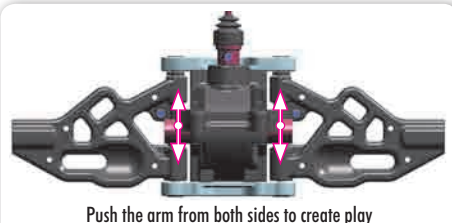
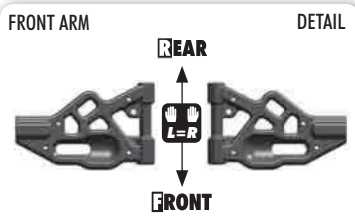

Eccentric bushings have two different offsets from the center.

- Middle position = 0.5 mm or 0.5° from center
- Outer position = 1 mm or 1° from center

The new XRAY alu front lower suspension holders provide even greater range of adjustment for the front suspension. Using different combinations of eccentric bushings, fine adjustment of front kick-up, roll center, and front track-width can be obtained. For more information about the influence of kick-up, front track-width, and roll centers on car handling, please refer to HUDY Off-Road Set-up Book (#209099).

TRACK-WIDTH		
FF	FR	(mm)
0, 0	0, 0	=308
0.5, 0.5	0.5, 0.5	=306
1, 1	1, 1	=310

ROLL CENTER		
FF	FR	(mm)
0, 0	0, 0	=1
0.5, 0.5	0.5, 0.5	=0
1, 1	1, 1	=-1

The tables below describe the amounts of kick-up, front track-width change depending on the combinations of eccentric bushings used with 0 and 1mm, 1° off set. The 0.5mm, 0.5° represent the half change.

**SET-UP BOOK**  
KICK UP  
ROLL CENTER  
DOWNSTOP  
WHEELBASE  
TRACK WIDTH

# FRONT SUSPENSION



901312  
SB M3x12

2x  
L=R

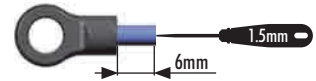
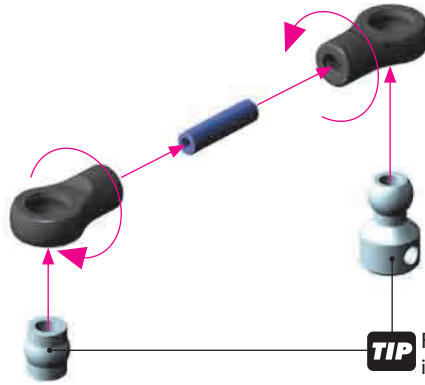

**TIP** Follow the TECH TIP on page 5 to install the pivot balls

901303  
SB M3x3

901305  
SB M3x5



902318  
SH M3x18



903308  
SFH M3x8

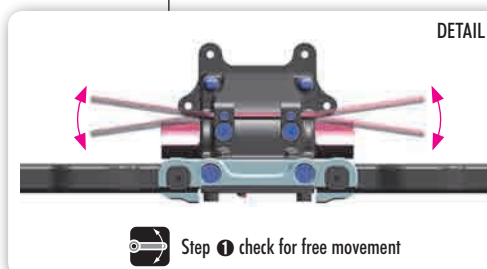
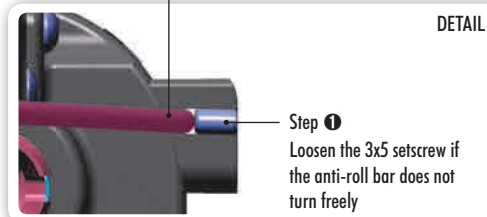
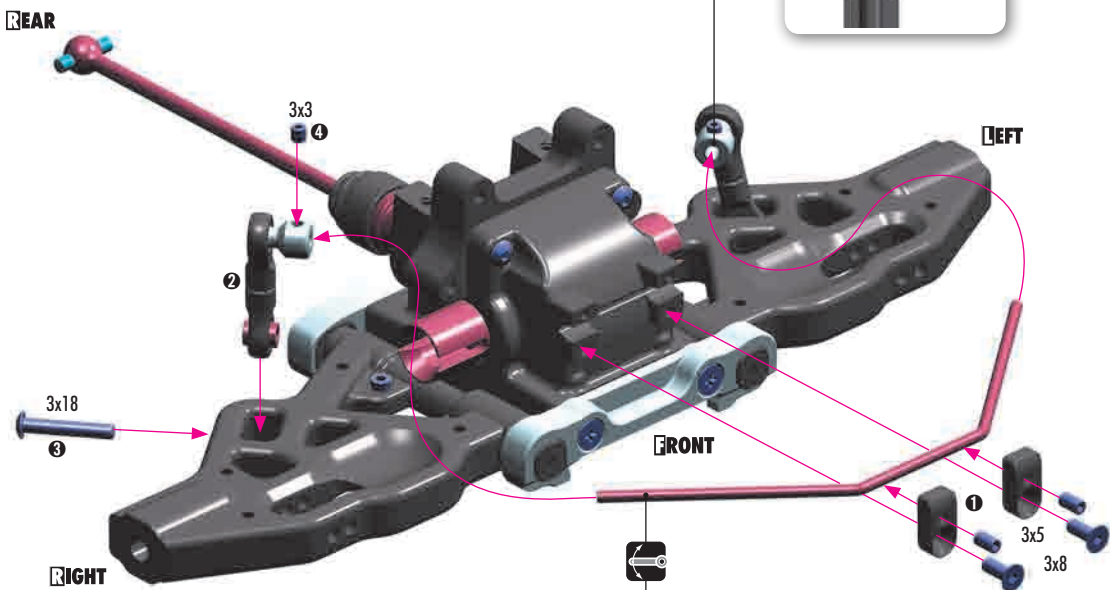

**SET-UP BOOK**

ANTI-ROLL BAR

# 6. FRONT SUSPENSION

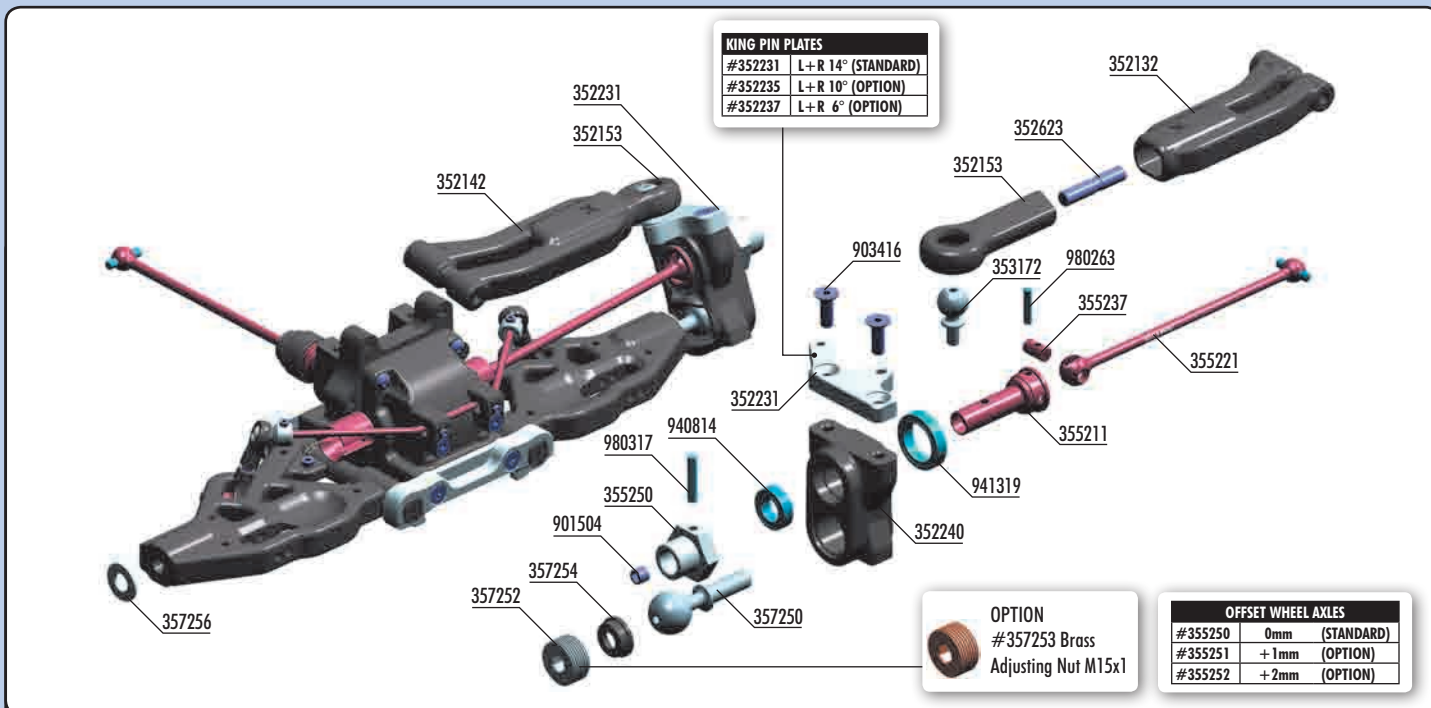

KING PIN PLATES	
#352231	L+R 14° (STANDARD)
#352235	L+R 10° (OPTION)
#352237	L+R 6° (OPTION)

OFFSET WHEEL AXLES	
#355250	0mm (STANDARD)
#355251	+1mm (OPTION)
#355252	+2mm (OPTION)

**OPTION**  
#357253 Brass  
Adjusting Nut M15x1

**BAG**  
**06**

- |         |   |         |  |
|---------|---|---------|--|
| 35 2132 | XB8 FRONT UPPER ARM RIGHT                                 | 35 7252 | ALU ADJUSTING NUT M15x1 (2)                      |
| 35 2142 | XB8 FRONT UPPER ARM LEFT                                  | 35 7253 | BRASS ADJUSTING NUT M15x1 (2) (OPTION)           |
| 35 2153 | XB8 FRONT UPPER ARM BALL JOINT (L+R)                      | 35 7254 | COMPOSITE BALL CUP 13.9 MM (2)                   |
| 35 2231 | XB8 ALU STEERING KING PIN PLATE - SWISS 7075 T6 - L+R 14° | 35 7256 | ALU SHIM 6x13x1 (2)                              |
| 35 2240 | XB8 STEERING BLOCK  | 90 1504 | HEX SCREW SB M5x4 (10)                           |
| 35 2623 | ADJ. TURNBUCKLE M5 L/R 28 MM - HUDY SPRING STEEL™ (2)     | 90 3416 | HEX SCREW SFH M4x16 (10)                         |
| 35 3172 | PIVOT BALL 11.0 (2)                                       | 94 0814 | HIGH-SPEED BALL-BEARING 8x14x4 BLUE COVERED (2)  |
| 35 5211 | CVD DRIVE AXLE - HUDY SPRING STEEL™                       | 94 1319 | HIGH-SPEED BALL-BEARING 13x19x4 BLUE COVERED (2) |
| 35 5221 | CVD UNIVERSAL DRIVE SHAFT - HUDY SPRING STEEL™            | 98 0263 | PIN 2.5x13 (10)                                  |
| 35 5237 | CVD DRIVE SHAFT COUPLING - HUDY SPRING STEEL™             | 98 0317 | PIN 3x17 (10)                                    |
| 35 5250 | ALU WHEEL AXLE - BLACK COATED (2)                         |         |  |
| 35 7250 | STEEL PIVOT BALL 13.9 MM (2)                              |         |  |

- 901504 SB M5x4
- 903416 SFH M4x16
- 941319 BB 13x19x4
- 940814 BB 8x14x4
- 980317 P 3x17
- 980263 P 2.5x13

**2x**

**KING PIN PLATES**

#352231	L+R 14° (STANDARD)
#352235	L+R 10° (OPTION)
#352237	L+R 6° (OPTION)

**OFFSET WHEEL AXLES**

#355250	0mm (STANDARD)
#355251	+1mm (OPTION)
#355252	+2mm (OPTION)

**TIP** Use HUDY Ball-Bearing Grease or Oil for servicing:  
 #106220 - Standard  
 #106221 - Extra  
 #106222 - Premium  
 #106230 - Bearing Oil

Graphite Grease (HUDY #106210)

**TIP** Follow the TECH TIP on page 5 for drive shaft pin servicing

**TIP** To tighten the setscrew you can also use the HUDY 17mm Wheel Nut Tool #107570

**ASSEMBLED VIEW**

**RIGHT**

# FRONT SUSPENSION

**2x** **L=R**

**TIP**  
Tighten composite hex nuts using HUDY tool #107581

**OPTION**  
#357253 Brass Adjusting Nut M15x1

**PIVOT BALLS MUST MOVE FREELY**  
During initial assembly, tighten each composite hex nut until the pivot ball starts to bind, then loosen slightly. Verify that the pivot balls move freely.

**IMPORTANT**  
Check that the pivot balls move freely after every run especially in dusty conditions.

**357256**  
SHIM 6x13x1

**2x** **L=R**

**TIP**  
HUDY Tool Allen 2.5mm

1mm

**RIGHT** **FRONT** **LEFT**

**SET-UP BOOK**  
CAMBER

**2x** **L=R**

**TIP** HUDY Tool Allen 2.5mm

**TIP** HUDY Tool Allen Ball 2.5mm

**CUTAWAY VIEW**

**DETAIL** 22mm

102.3mm

102.3mm

**LEFT** **RIGHT**

Marked (L) = Marked (L)

Marked (R) = Marked (R)

**353380**  
SHIM 4x7.5x1

**353381**  
SHIM 4x7.5x2

**2x** **L=R**

**TIP** If the front upper arm does not move freely use a HUDY Arm Reamer to resize the holes of the arms. (HUDY #107634)

**OPTION** shims from the Last Aid Bag can be used for Roll Center adjustment.  
#353380 - Alu shim 4x7.5x1mm  
#353381 - Alu shim 4x7.5x2mm

Apply WD-40 to protect against rust

**RIGHT** **FRONT** **LEFT**

**SET-UP BOOK**  
ROLL CENTER

# FRONT & REAR ASSEMBLY

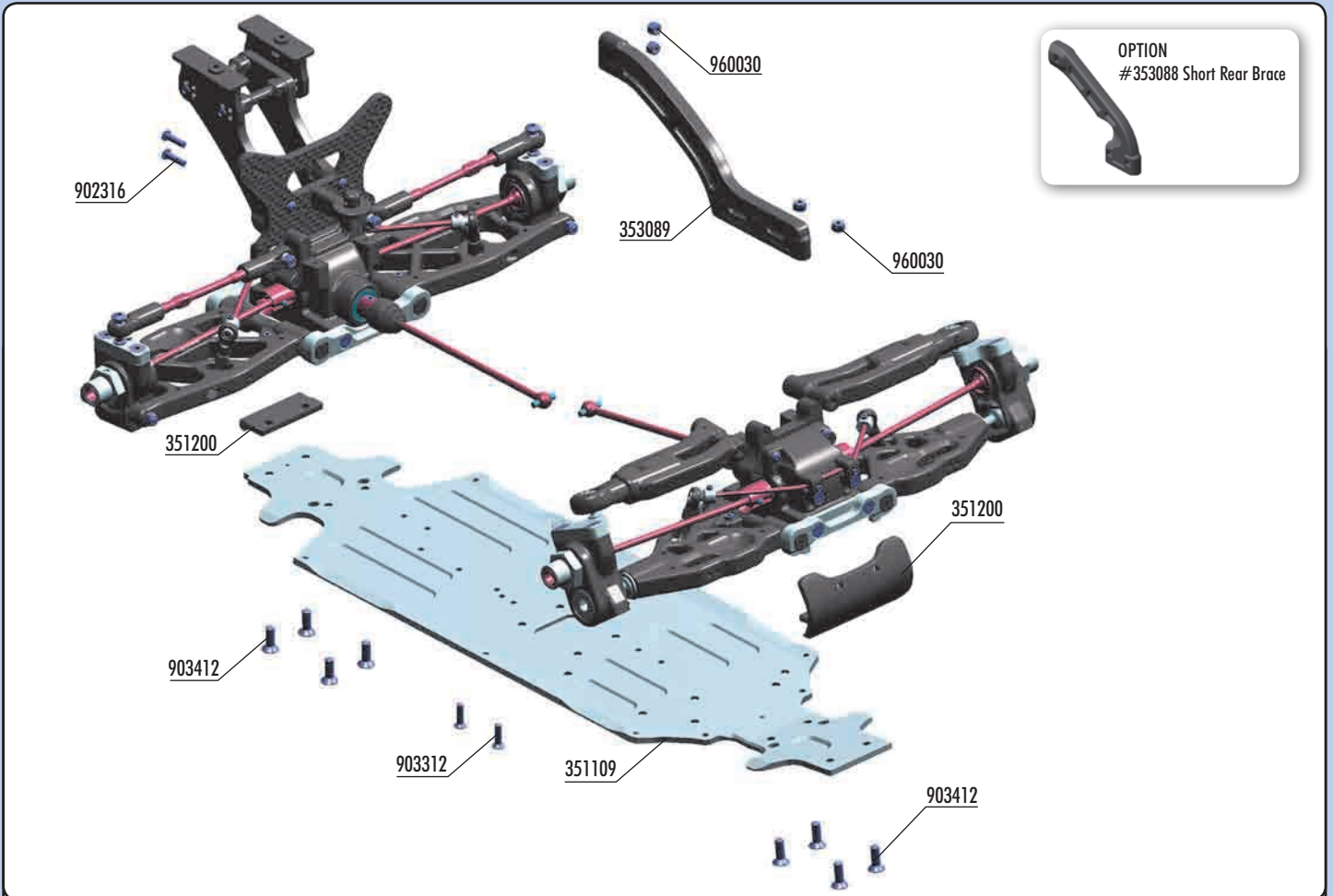

**BAG**

**06**

35 1109	XB8E ALU CHASSIS - SWISS 7075 T6 (3MM) - HARD COATED	90 2316	HEX SCREW SH M3x16 (10)
35 1200	FRONT & REAR BUMPER - V2	90 3312	HEX SCREW SFH M3x12 (10)
35 3088	COMPOSITE REAR BRACE - V2 (OPTION)	90 3412	HEX SCREW SFH M4x12 (10)
35 3089	COMPOSITE REAR BRACE - LONG	96 0030	NUT M3 (10)



903412  
SFH M4x12

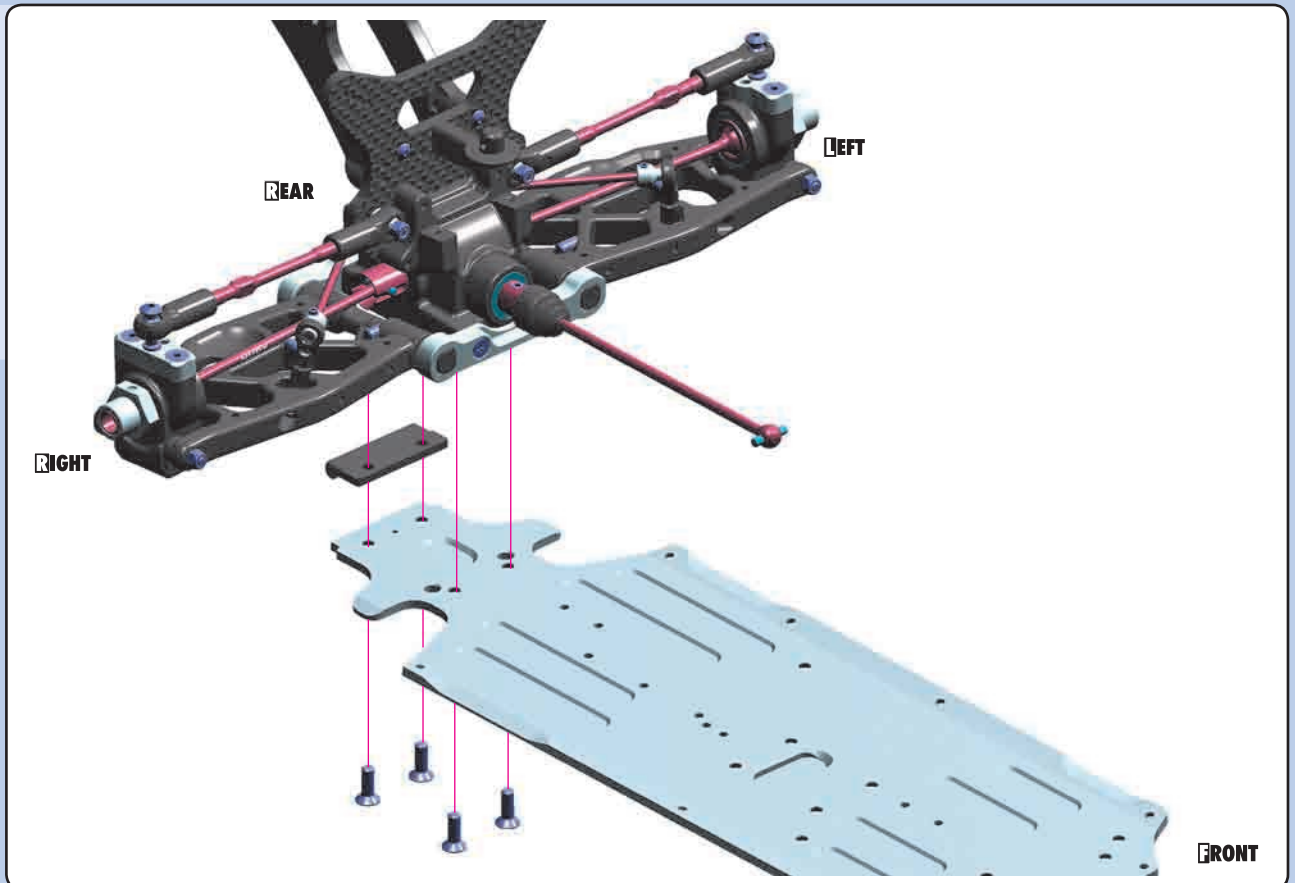

# FRONT & REAR ASSEMBLY



902316  
SH M3x16



903312  
SFH M3x12



960030  
N M3

**RIGHT**

**REAR**

**FRONT**

3x16

3x12

Screw from the Last Aid Bag can be used for extra stiffness adjustment

**INITIAL SETTING**

Add for extra stiffness (use from Last Aid Bag)

**OPTION**  
#358088 Short Rear Brace

REAR BRACES	TRACK TYPE		
	FLAT	MEDIUM JUMPS	LARGE JUMPS
Long Brace	✓	✓	✓
Short Brace	✗	✗	✓



903412  
SFH M4x12

**REAR**

**FRONT**

**DETAIL**

**FRONT**

# 7. STEERING

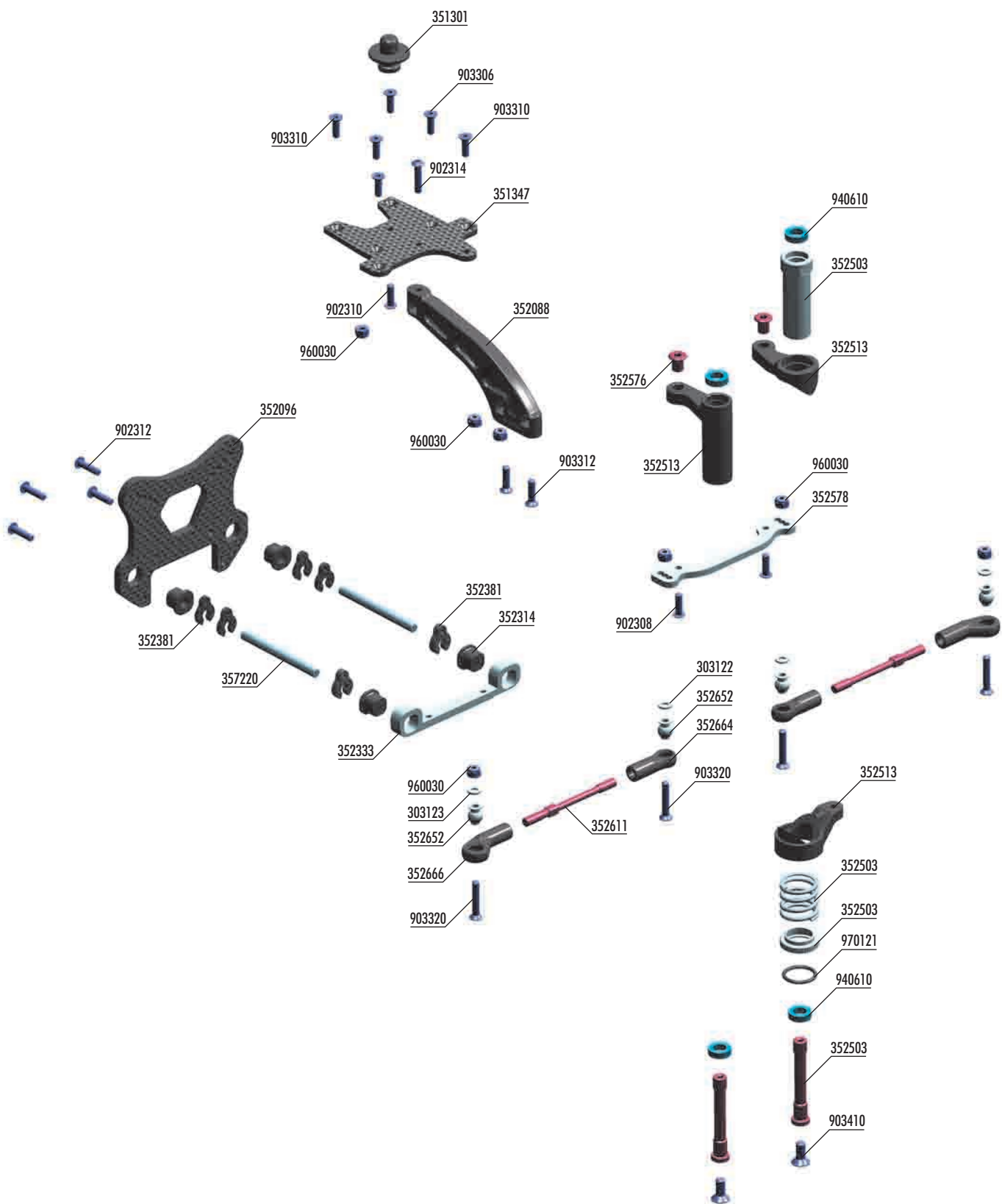

**BAG**

**07**

30 3122	ALU SHIM 3x6x1.0MM (10)	35 2664	COMPOSITE STEERING BALL JOINT 6.8MM - V3 (2)
30 3123	ALU SHIM 3x6x2.0MM (10)	35 2666	COMPOSITE RELIEF STEERING BALL JOINT 6.8MM (2)
35 1301	BODY POSTS	35 7220	FRONT UPPER PIVOT PIN (2)
35 1347	XB8 GRAPHITE UPPER PLATE	90 2308	HEX SCREW SH M3x8 (10)
35 2088	COMPOSITE FRONT BRACE	90 2310	HEX SCREW SH M3x10 (10)
35 2096	XB8 GRAPHITE FRONT SHOCK TOWER - CNC MACHINED 4 MM	90 2312	HEX SCREW SH M3x12 (10)
35 2314	COMPOSITE SQUARE ADJ. ROLL-CENTER BUSHINGS - V2 (2)	90 2314	HEX SCREW SH M3x14 (10)
35 2333	XB8 ALU FRONT UPPER ARM HOLDER - SWISS 7075 T6 (6MM)	90 3306	HEX SCREW SFH M3x6 (10)
35 2381	XB8 CASTER CLIPS (2)	90 3310	HEX SCREW SFH M3x10 (10)
35 2503	XB8 SERVO SAVER COMPLETE SET	90 3312	HEX SCREW SFH M3x12 (10)
35 2513	XB8 COMPOSITE SERVO SAVER	90 3320	HEX SCREW SFH M3x20 (10)
35 2576	STEERING PLATE BUSHING (2)	90 3410	HEX SCREW SFH M4x10 (10)
35 2578	XB8 ALU STEERING PLATE - SWISS 7075 T6	94 0610	HIGH-SPEED BALL-BEARING 6x10x3 BLUE COVERED (2)
35 2611	ADJ. TURNBUCKLE M4 L/R 52.5 MM - HUDY SPRING STEEL (2)	96 0030	NUT M3 (10)
35 2652	BALL STUD 6.8MM (4)	97 0121	O-RING 12.1 x 1.6 (10)



902308  
SH M3x8

940610  
BB 6x1.0x3

970121  
O 12.1x1.6

903410  
SFH M4x10

**SET-UP BOOK**  
SERVO SAVER

### step 1

INITIAL PRELOAD SETTING  
4~5mm

### step 2

**TIP** HUDY Tool Allen 3.0mm

3x8

3x8

**NOTE ORIENTATION**

### step 3

For servicing use Bearing Oil (HUDY #106230)

FRONT

4x10

**NOTE ORIENTATION**

902310  
SH M3x10

902312  
SFH M3x12

902314  
SH M3x14

903306  
SFH M3x6

903310  
SFH M3x10

960030  
N M3

**SET-UP BOOK**  
ROLL CENTER

### ASSEMBLED VIEW

Composite eccentric bushings

3x6

3x10

**INITIAL SETTINGS**

1 0.5 0 0.5 1

All possible mounting alternatives of eccentric bushings

**NOTE ORIENTATION**

INITIAL POSITION

3x10

3x10

3x14

3x12

**NOTE ORIENTATION**

**TIP** Follow the TECH TIP on page 5 to install the pivot balls

**NOTE ORIENTATION**

LEFT THREAD

RIGHT THREAD

Right thread ← 32.2 mm → Left thread

**LEFT**

**TIP** Follow the TECH TIP on page 5 to install the pivot balls

**NOTE ORIENTATION**

RIGHT THREAD

LEFT THREAD

Left thread ← 32.2 mm → Right thread

**RIGHT**

# STEERING



902312  
SH M3x12

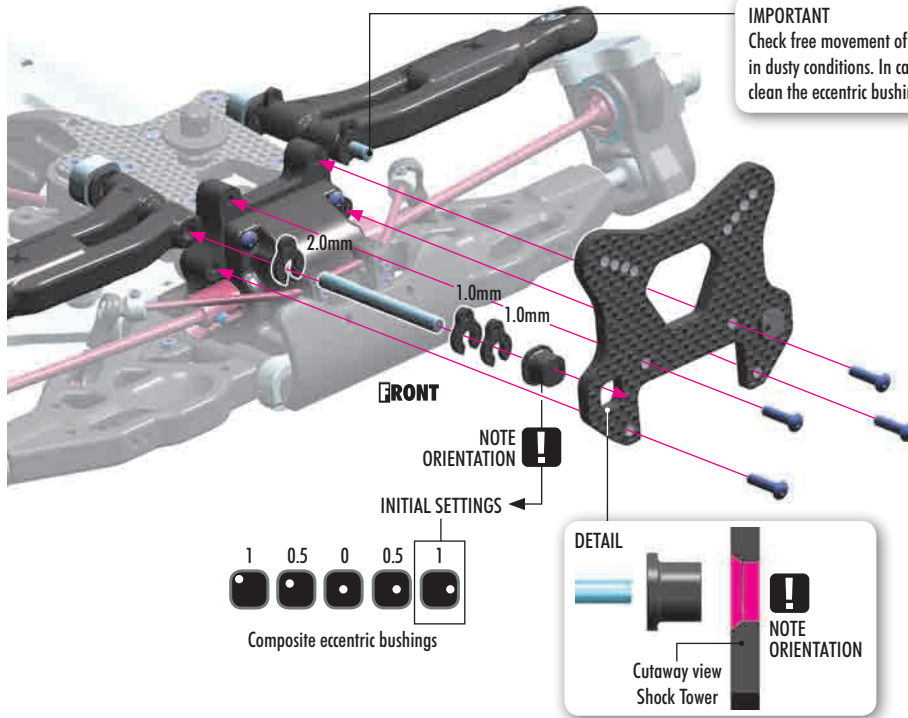

**IMPORTANT**  
Check free movement of the front upper arm after every run especially in dusty conditions. In case of binding resize the front upper arm and/or clean the eccentric bushings.

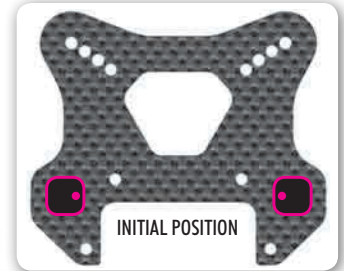

All possible mounting alternatives of eccentric bushings

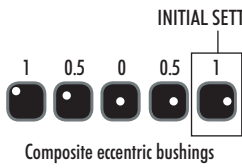
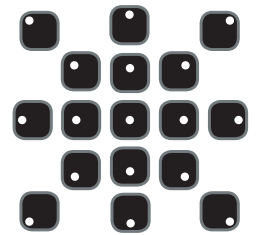

Composite eccentric bushings

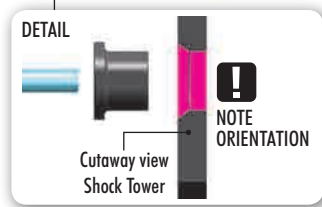

CASTER		
UPPER CLIP (Behind arm)	LOWER SHIM (Behind arm)	
		2mm
4mm	24°	21°
3mm	25.5°	22.5°
2mm	27°	24°
1mm	28.5°	25.5°
0	30°	27°

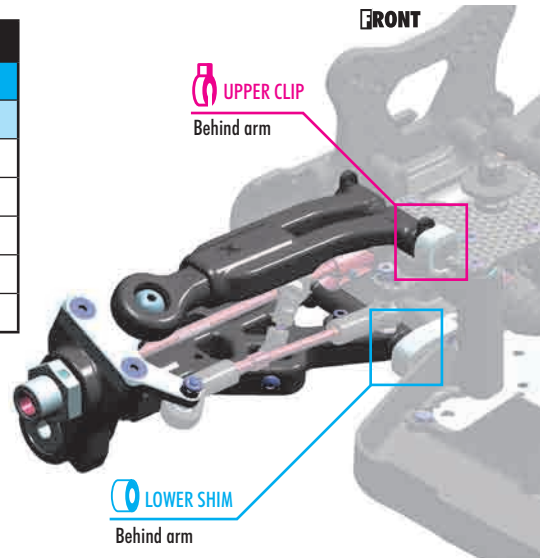
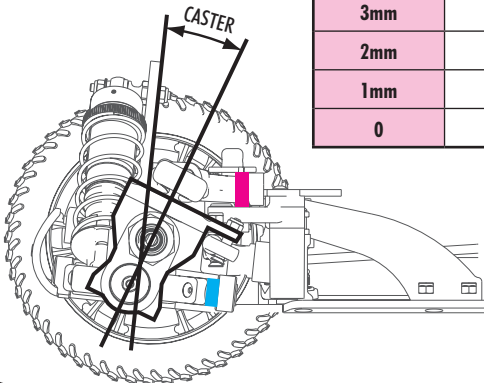

**SET-UP BOOK**  
ROLL CENTER  
CASTER



303122 SHIM 3x6x1  
303123 SHIM 3x6x2



903320 SFH M3x20  
960030 N M3

**SET-UP BOOK**  
ACKERMANN  
BUMP STEER  
TOE-IN

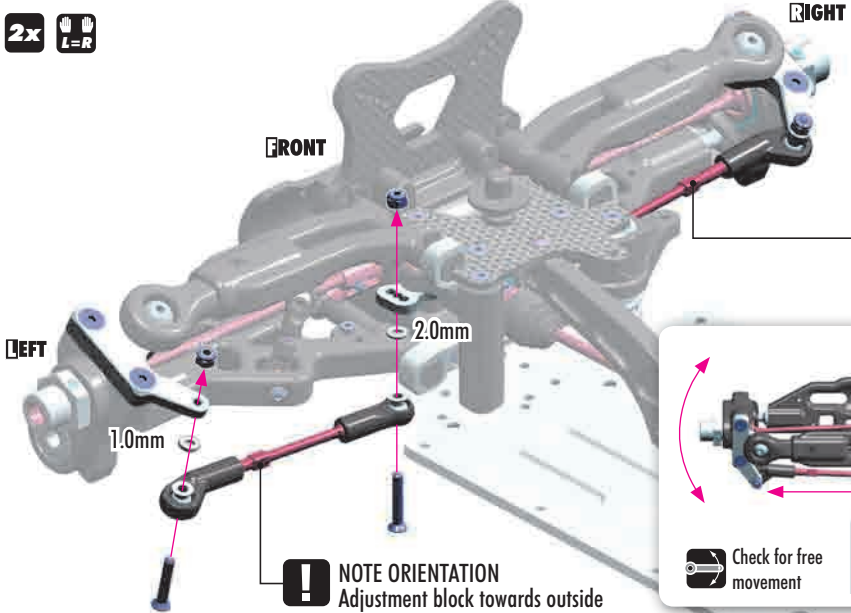

**NOTE ORIENTATION**  
Adjustment block towards outside

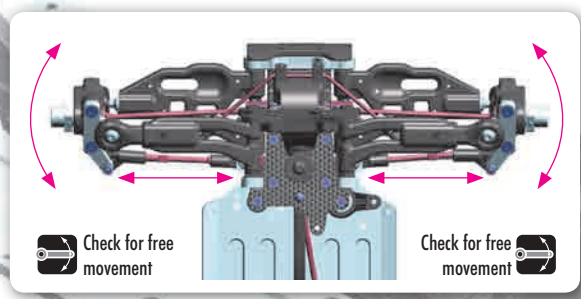

# 8. CENTER DIFF & MOTOR

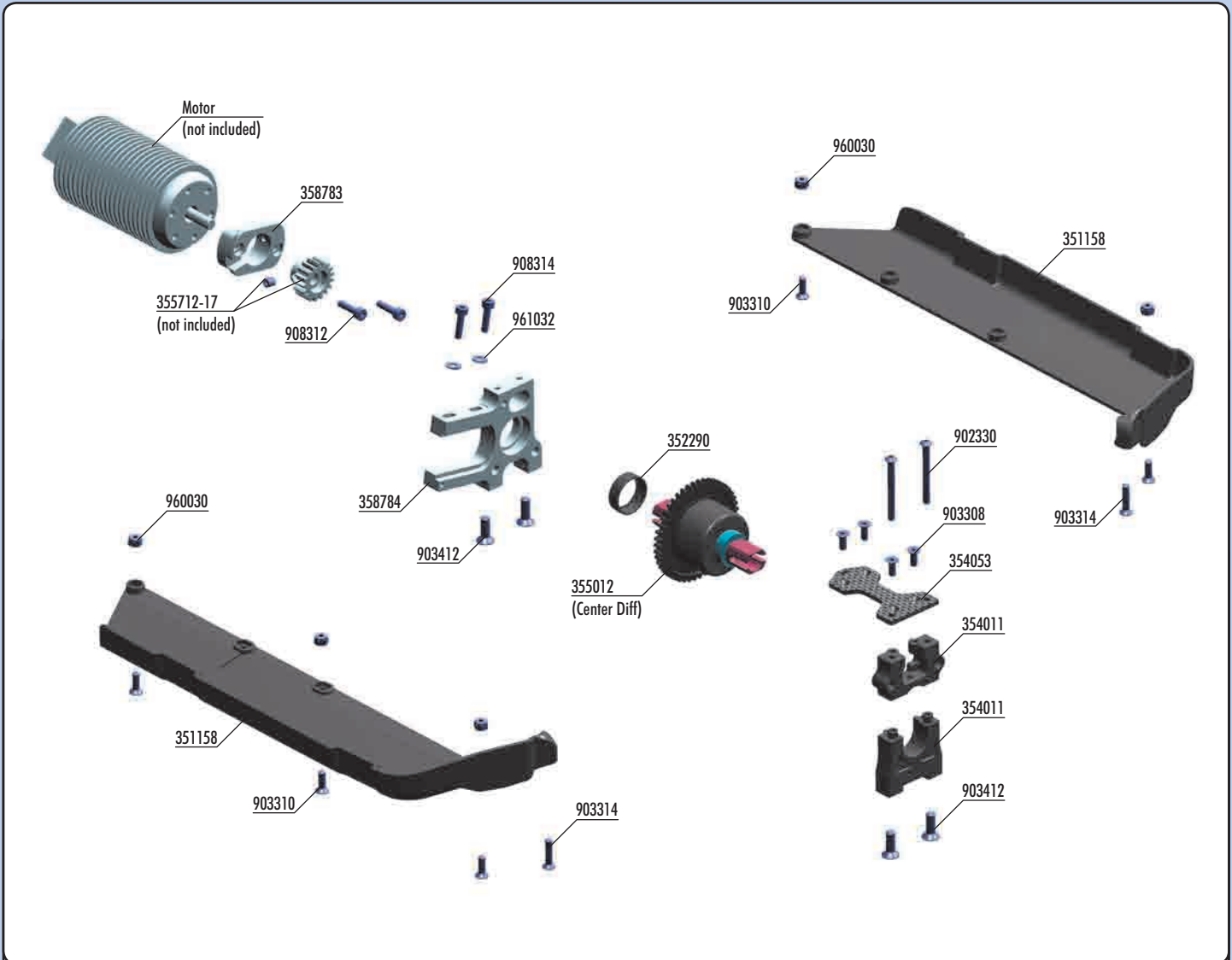

**BAG**

**08**

- 35 1158 XB8 CHASSIS SIDE GUARDS L+R W/OUT RIB
- 35 2290 COMPOSITE BUSHING FOR ALU STEERING BLOC (4)
- 35 4011 CENTER DIFF MOUNTING PLATE SET - HIGHER
- 35 4053 XB9E GRAPHITE CENTER DIFF MOUNTING PLATE
- 35 5712~17 XB808E 12~17T PINION GEAR (OPTION)
- 35 8783 XB9E ALU MOTOR MOUNT PLATE
- 35 8784 XB8E ALU MOTOR MOUNT
- 90 2330 HEX SCREW SH M3x30 (10)

- 90 3308 HEX SCREW SFH M3x8 (10)
- 90 3310 HEX SCREW SFH M3x10 (10)
- 90 3314 HEX SCREW SFH M3x14 (10)
- 90 3412 HEX SCREW SFH M4x12 (10)
- 90 8312 HEX SCREW SOCKET HEAD CAP M3x12 (10)
- 90 8314 HEX SCREW SOCKET HEAD CAP M3x14 (10)
- 96 0030 NUT M3 (10)
- 96 1032 WASHER S 3.2 (10)



908312  
SCH M3x12

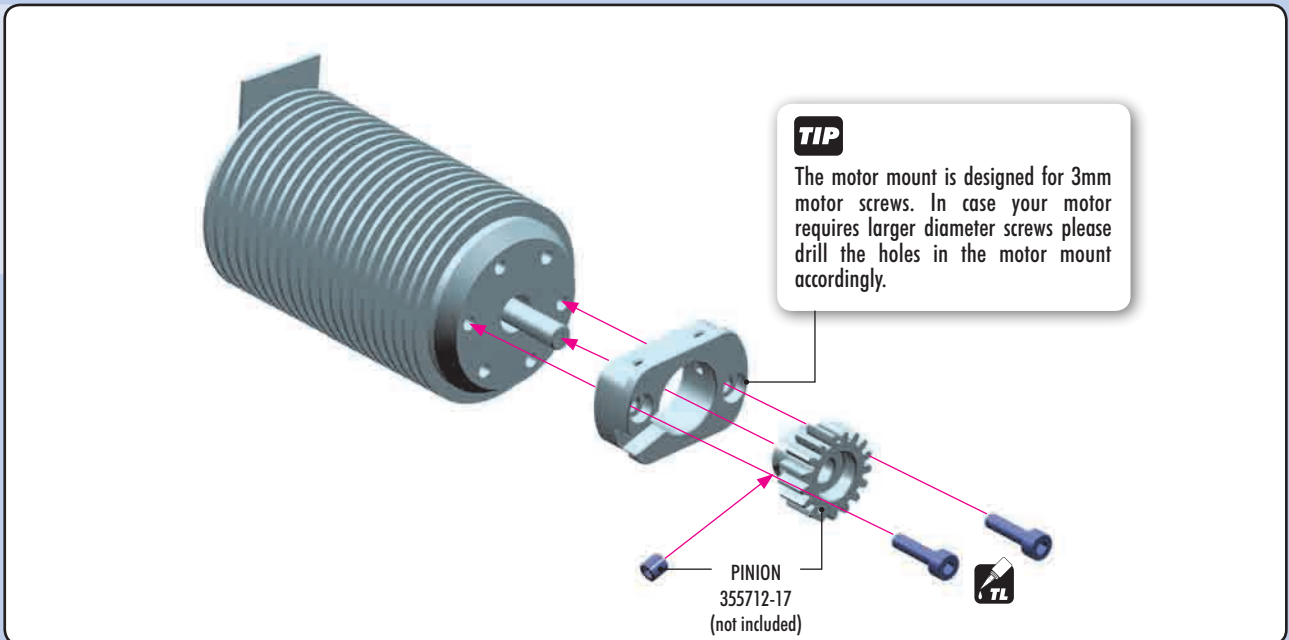

**TIP**  
The motor mount is designed for 3mm motor screws. In case your motor requires larger diameter screws please drill the holes in the motor mount accordingly.

PINION  
355712-17  
(not included)

# CENTER DIFF & MOTOR

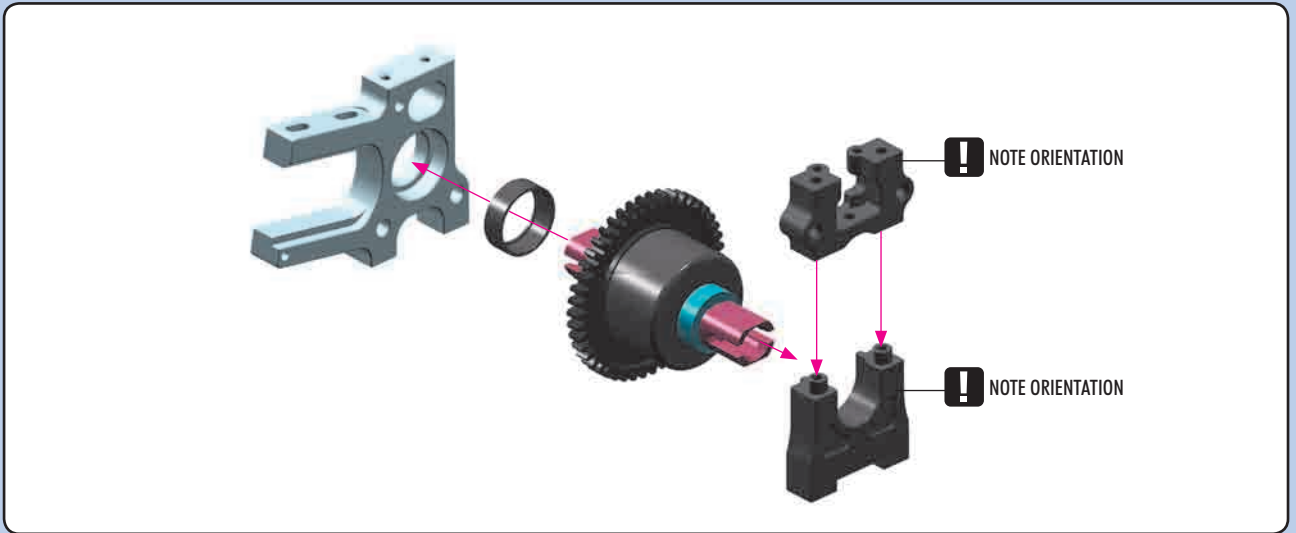

- 

902330  
SFH M3x30
- 

903308  
SFH M3x8

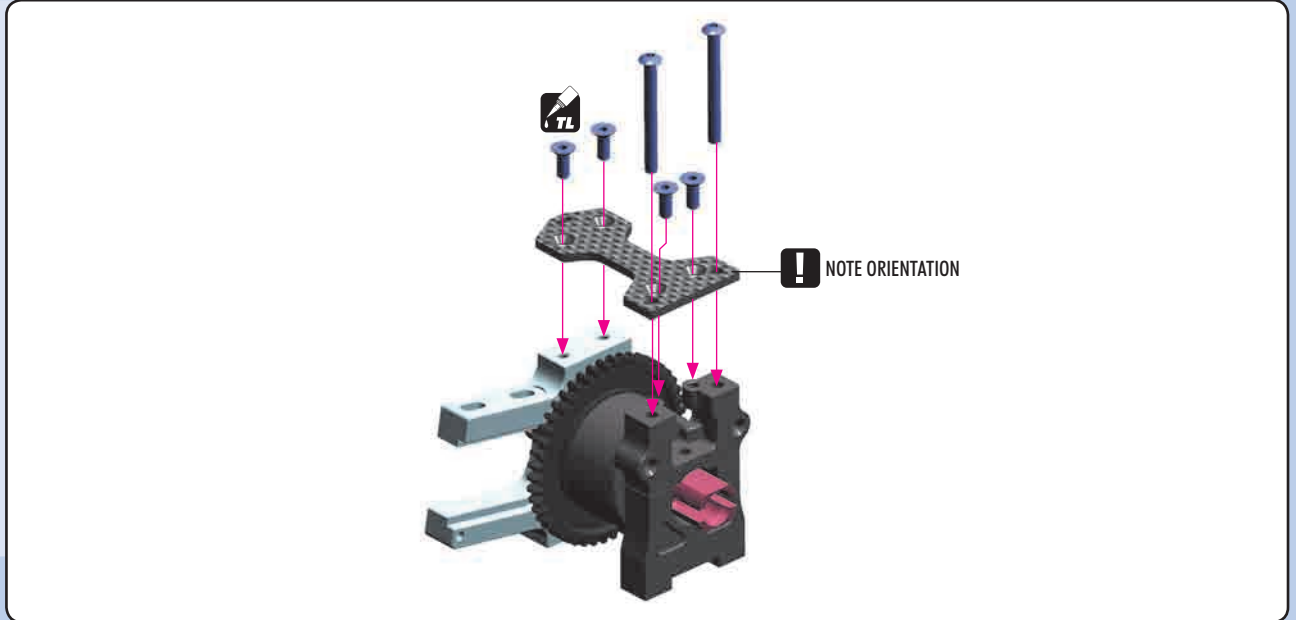

- 

903412  
SFH M4x12

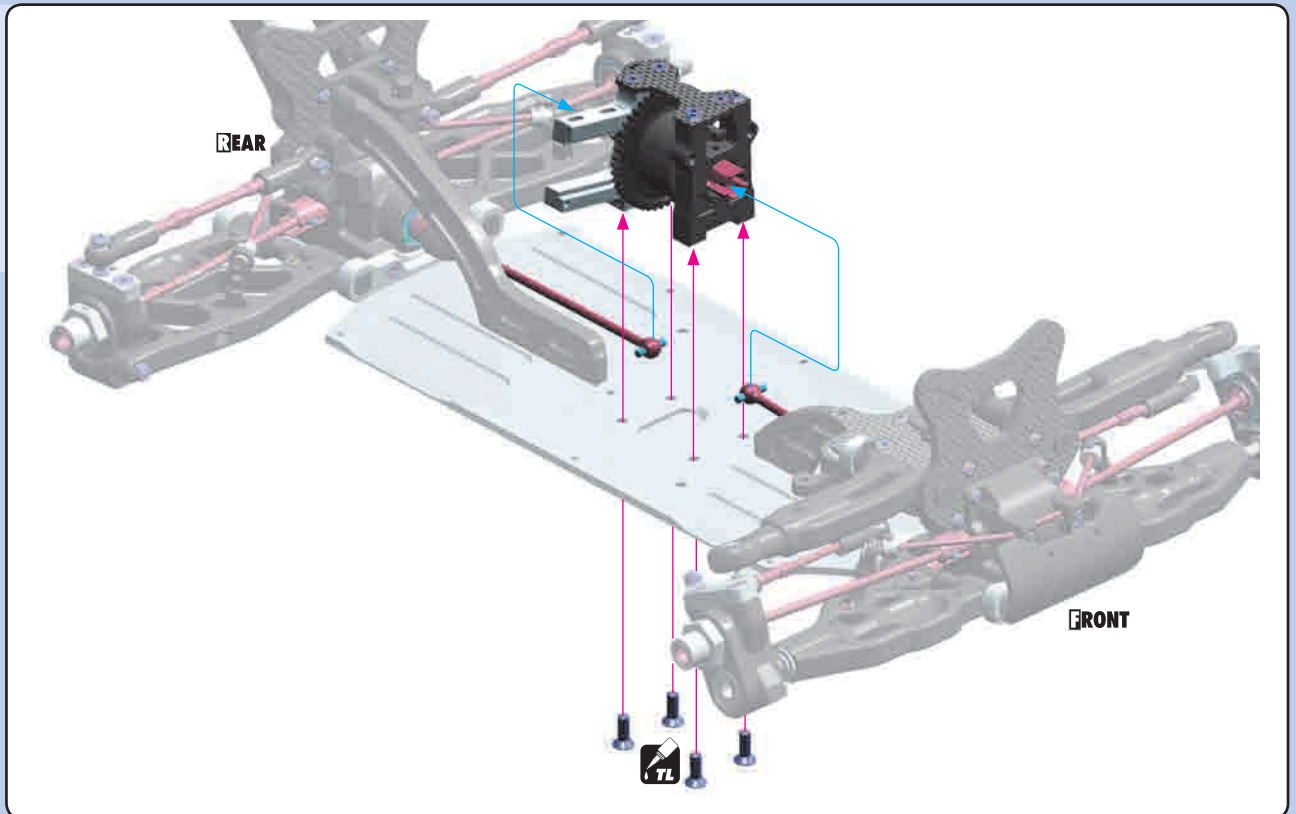

# CENTER DIFF & MOTOR



908314  
SCH M3x14



961032  
S 3.2

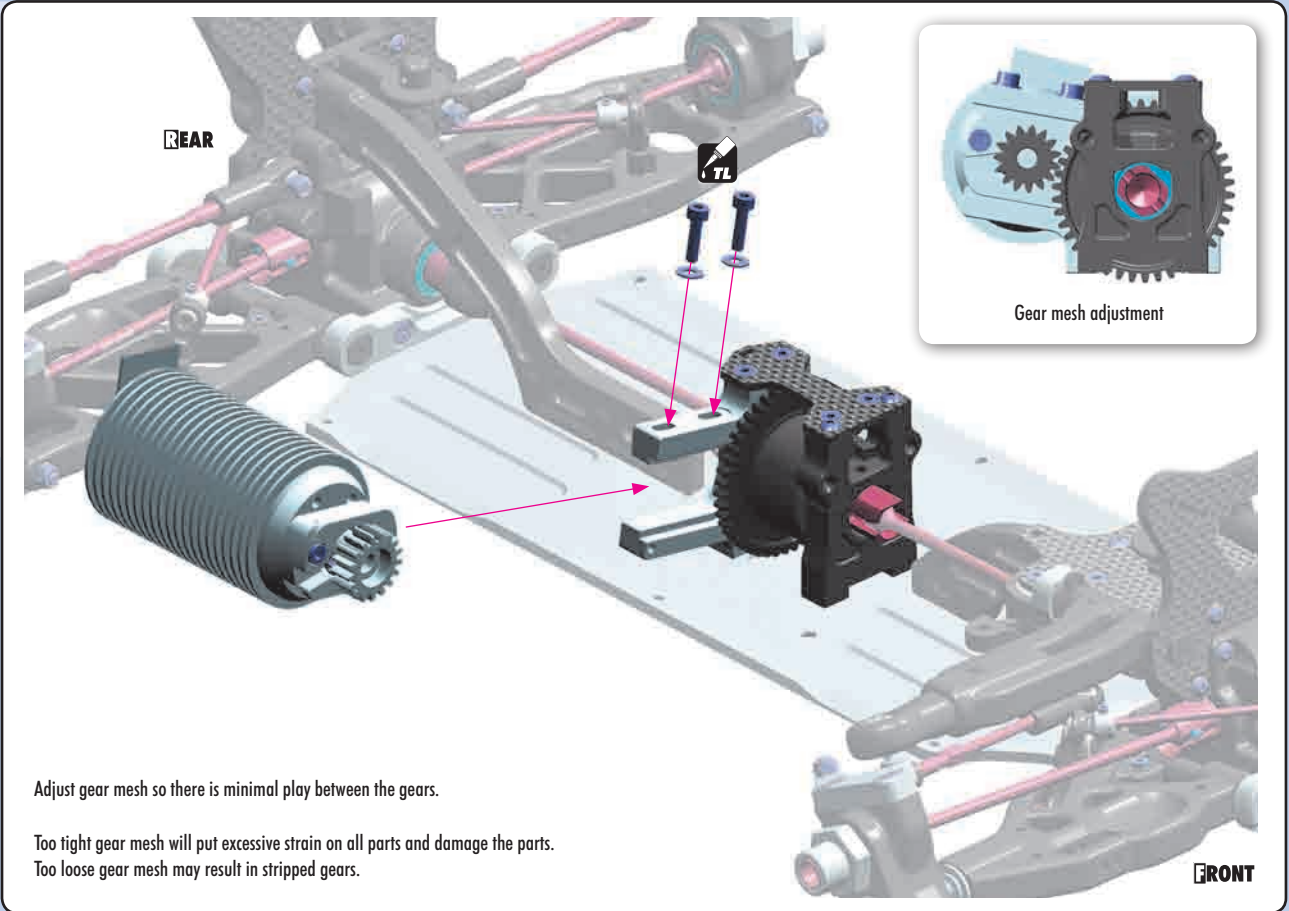

903310  
SFH M3x10



903314  
SFH M3x14



960030  
N M3

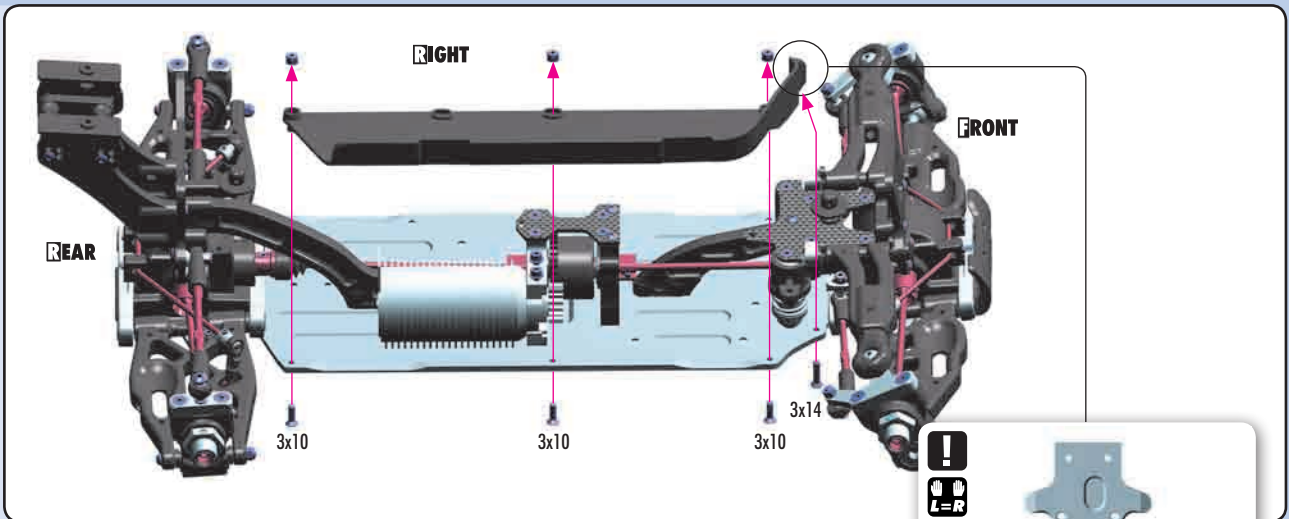

903310  
SFH M3x10



903314  
SFH M3x14



960030  
N M3

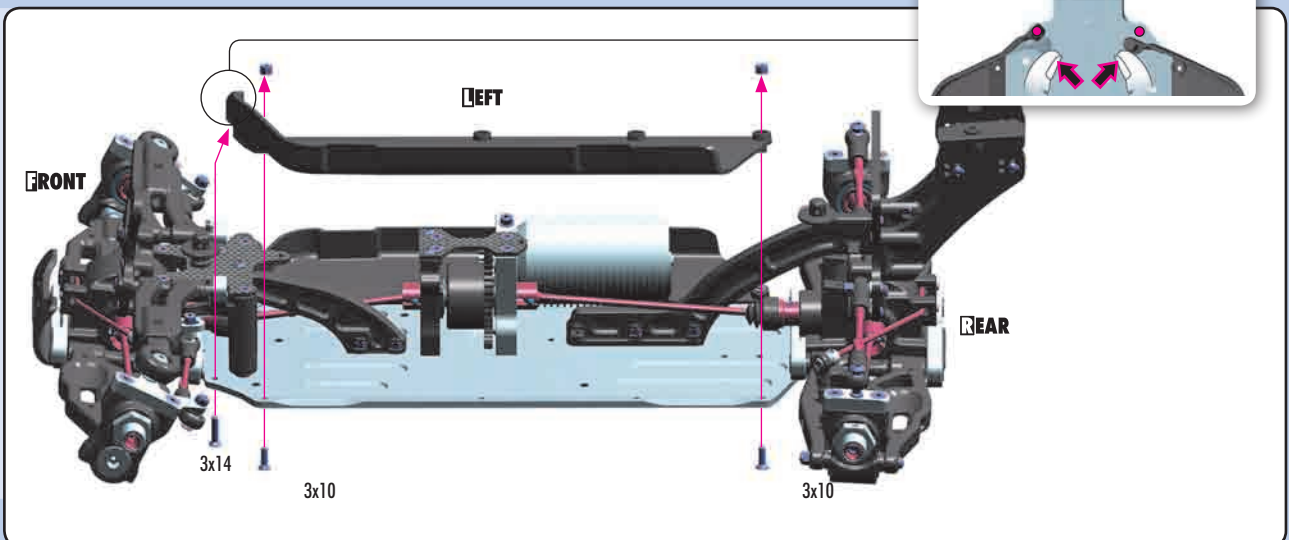

# 10. RADIO CASE

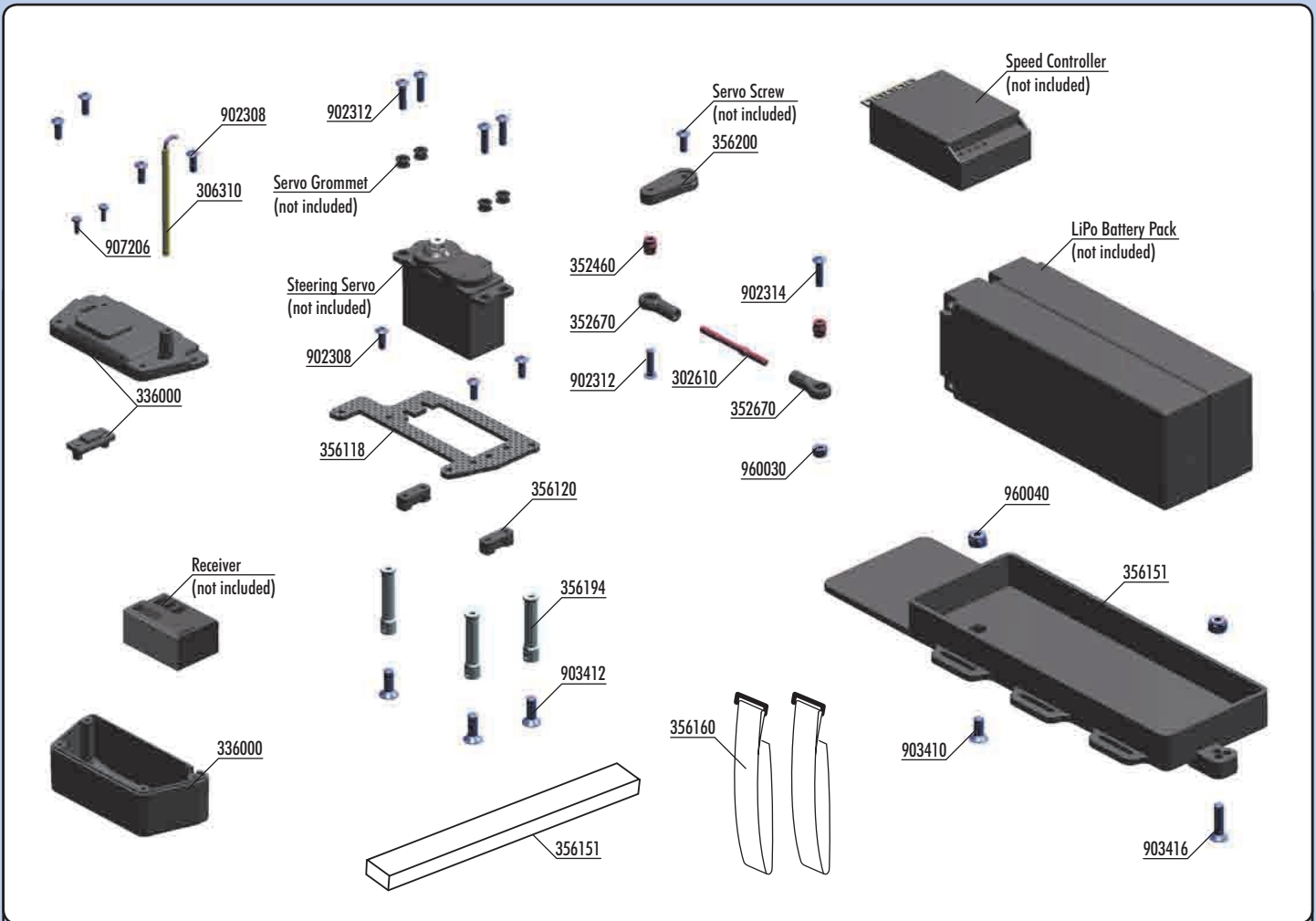

- 30 2610 ADJ. TURNBUCKLE L/R 40 MM - HUDY SPRING STEEL (2)
- 30 6310 ANTENNA TUBE (2)
- 33 6000 COMPOSITE RECEIVER CASE - V2
- 33 6060 RECEIVER SWITCH - SET (OPTION)
- 35 2460 PIVOT BALL 5.8 (10)
- 35 2670 SERVO BALL JOINT 5.8MM (4)
- 35 6118 XB9E GRAPHITE RECEIVER CASE TOP PLATE
- 35 6120 STEERING SERVO MOUNT - SET
- 35 6151 XB9E COMPOSITE BATTERY PLATE
- 35 6160 VELCRO BATTERY STRAP 20x300MM (2)
- 35 6194 XB9E ALU MOUNT FOR RECEIVER BOX
- 35 6200 BRAKE/THROTTLE ARMS & STEERING SERVO ARMS - SET

- 38 9135 CONNECTING CABLE RECEIVER/BATT. PACK (OPTION)
- 90 2308 HEX SCREW SH M3x8 (10)
- 90 2312 HEX SCREW SH M3x12 (10)
- 90 2314 HEX SCREW SH M3x14 (10)
- 90 3410 HEX SCREW SFH M4x10 (10)
- 90 3412 HEX SCREW SFH M4x12 (10)
- 90 3416 HEX SCREW SFH M4x16 (10)
- 90 7206 SCREW PHILLIPS 2x6 (10)
- 96 0030 NUT M3 (10)
- 96 0040 NUT M4 (10)



902312  
SH M3x12

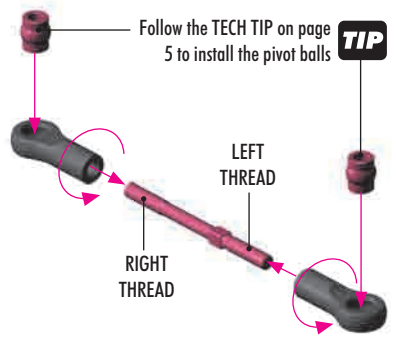

The length of the linkages varies according to the type of servo.

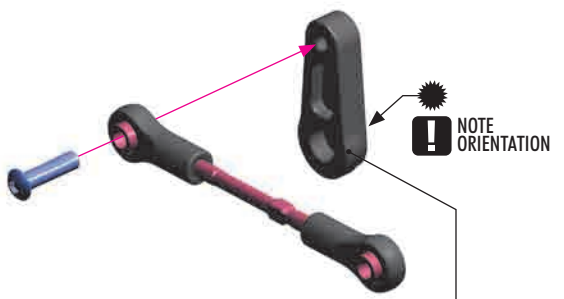

Use appropriate servo arm:  
K - (23T) H - (24T) F - (25T)

HUDY ALU SERVO HORNS	
#293501	23T KO Propo, Airtronics, JR, Sanwa (OPTION)
#293502	24T Hitec (OPTION)
#293503	25T Futaba (OPTION)



902312  
SH M3x12

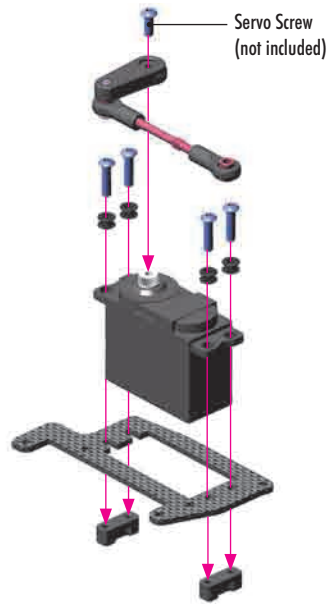

902308  
SH M3x8



907206  
Zx6

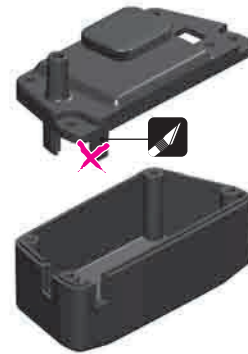
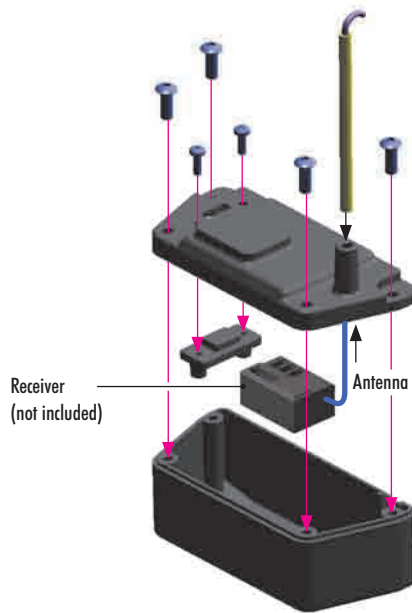

If the receiver box has 2 different-size openings for cable entry (narrow and wider), cut away the tab for the appropriate opening to allow the cables to fit properly.

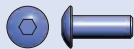

902308  
SH M3x8

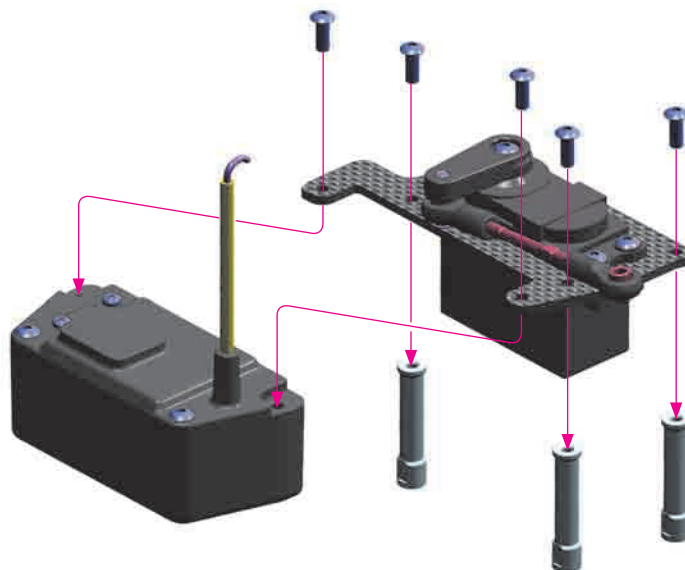

# RADIO CASE



902314  
SH M3x14



903410  
SFH M4x10



960030  
N M3

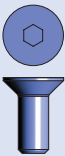
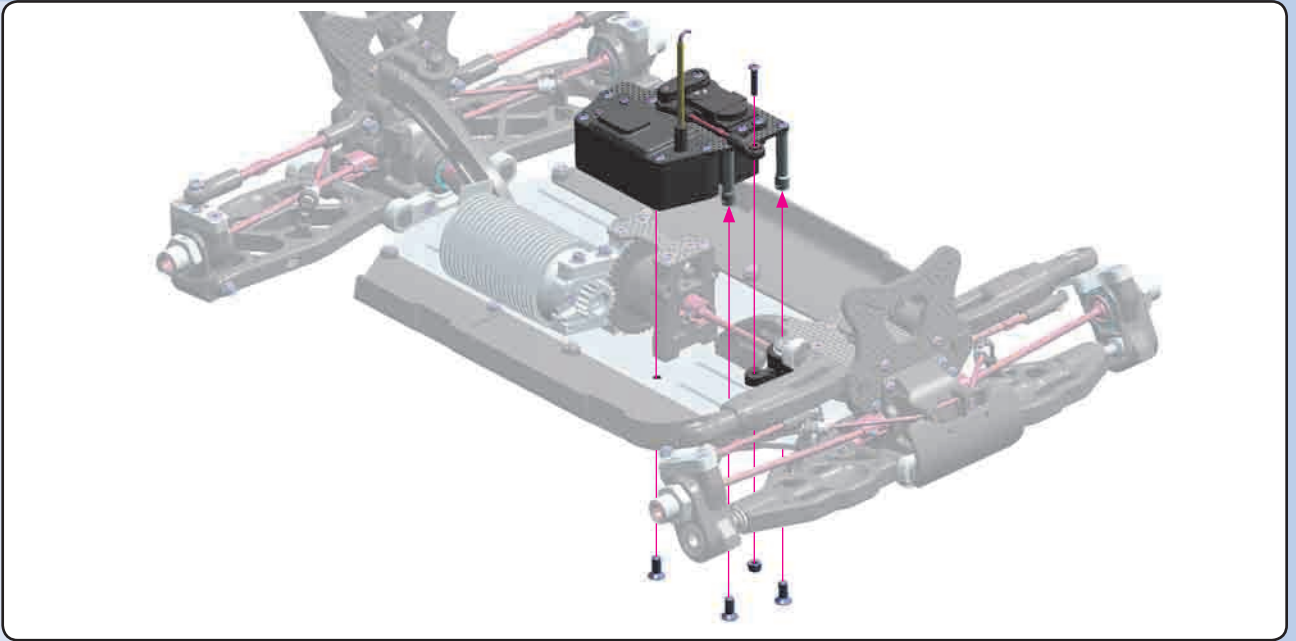

903410  
SFH M4x10



903416  
SFH M4x16



960040  
N M4

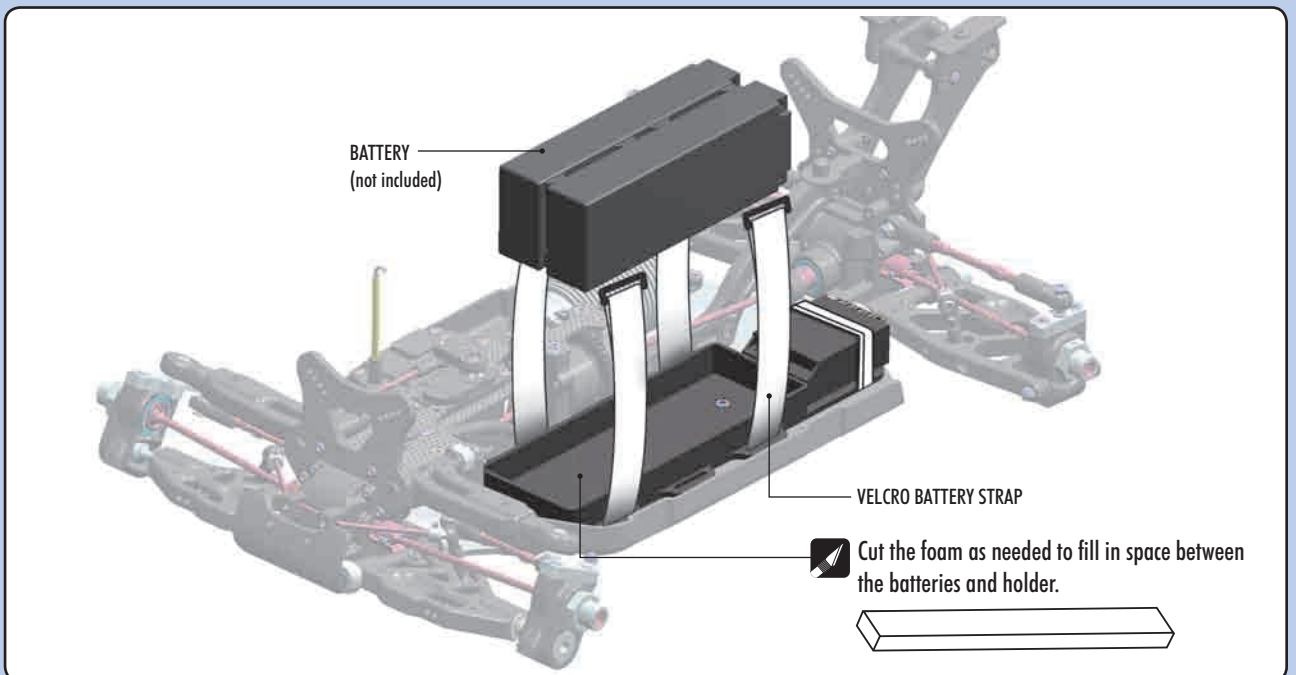
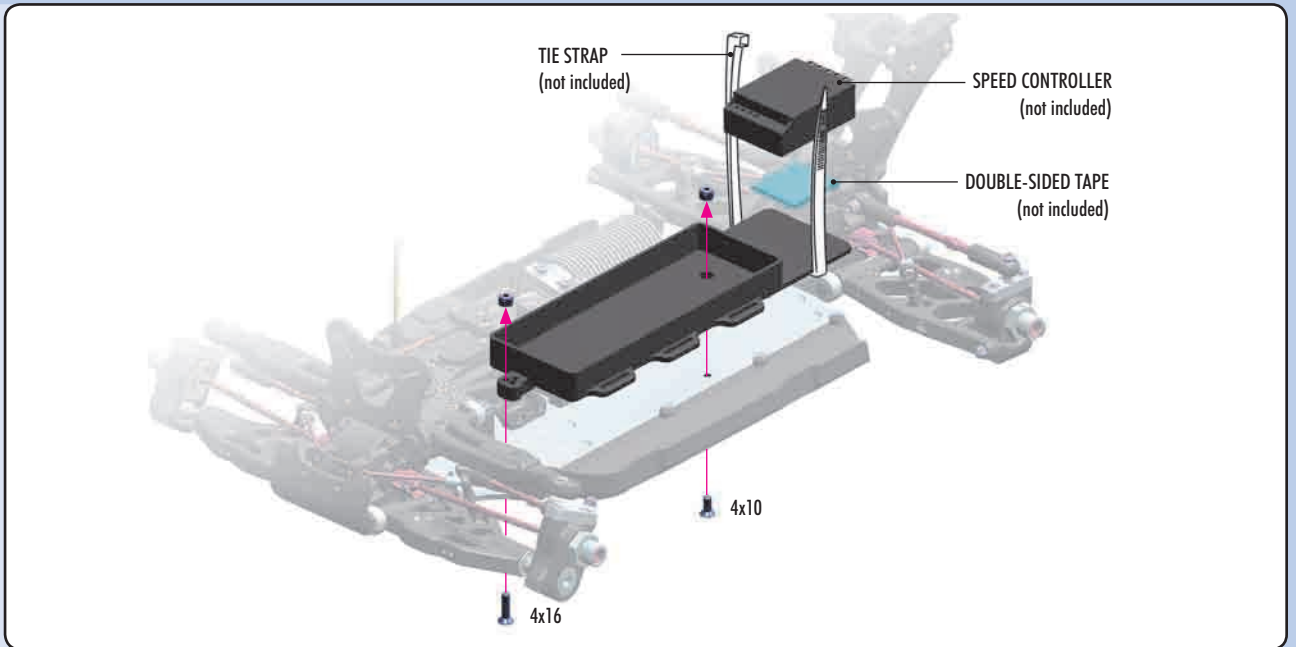



# 11. SHOCK ABSORBERS

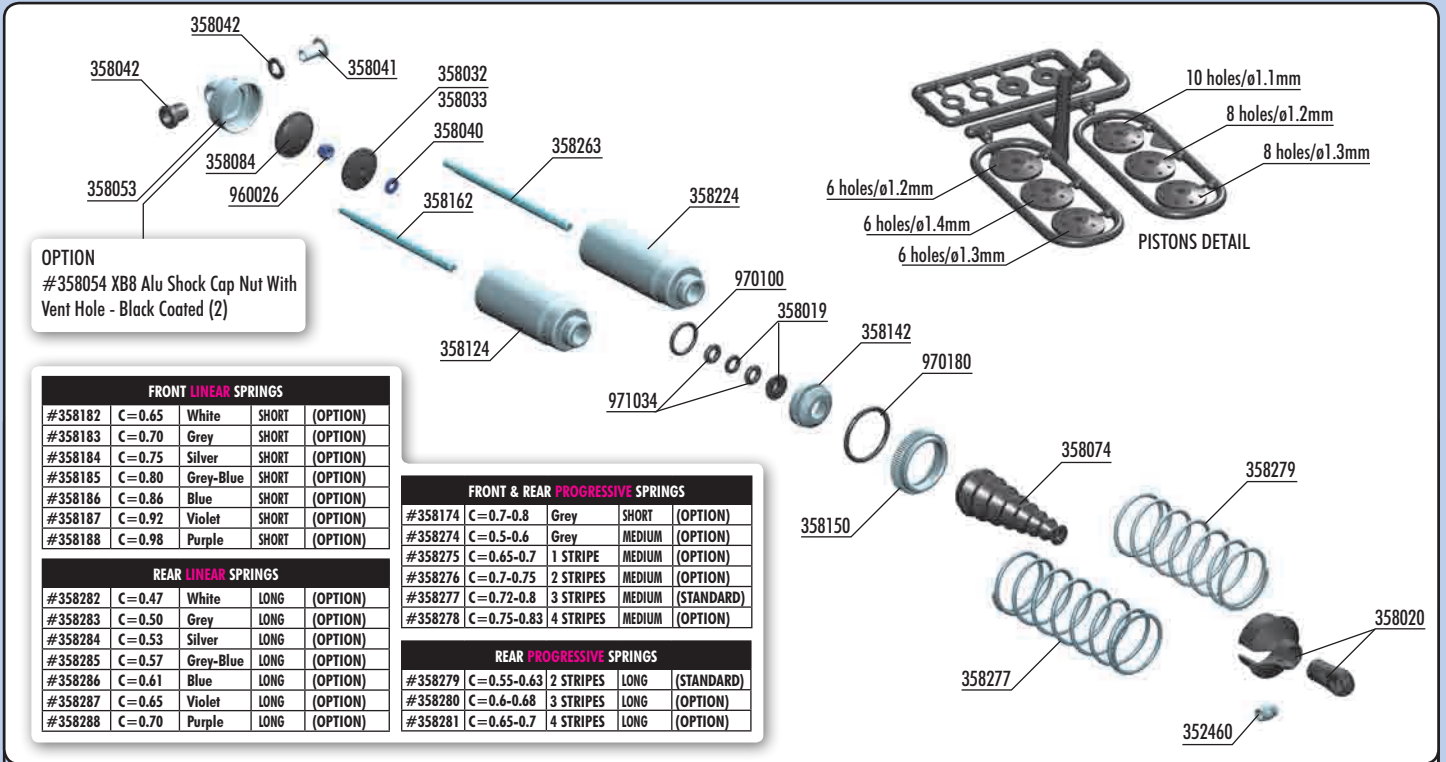

**OPTION**  
#358054 XB8 Alu Shock Cap Nut With Vent Hole - Black Coated (2)

FRONT LINEAR SPRINGS				
#358182	C=0.65	White	SHORT	(OPTION)
#358183	C=0.70	Grey	SHORT	(OPTION)
#358184	C=0.75	Silver	SHORT	(OPTION)
#358185	C=0.80	Grey-Blue	SHORT	(OPTION)
#358186	C=0.86	Blue	SHORT	(OPTION)
#358187	C=0.92	Violet	SHORT	(OPTION)
#358188	C=0.98	Purple	SHORT	(OPTION)

REAR LINEAR SPRINGS				
#358282	C=0.47	White	LONG	(OPTION)
#358283	C=0.50	Grey	LONG	(OPTION)
#358284	C=0.53	Silver	LONG	(OPTION)
#358285	C=0.57	Grey-Blue	LONG	(OPTION)
#358286	C=0.61	Blue	LONG	(OPTION)
#358287	C=0.65	Violet	LONG	(OPTION)
#358288	C=0.70	Purple	LONG	(OPTION)

FRONT & REAR PROGRESSIVE SPRINGS				
#358174	C=0.7-0.8	Grey	SHORT	(OPTION)
#358274	C=0.5-0.6	Grey	MEDIUM	(OPTION)
#358275	C=0.65-0.7	1 STRIPE	MEDIUM	(OPTION)
#358276	C=0.7-0.75	2 STRIPES	MEDIUM	(OPTION)
#358277	C=0.72-0.8	3 STRIPES	MEDIUM	(STANDARD)
#358278	C=0.75-0.83	4 STRIPES	MEDIUM	(OPTION)

REAR PROGRESSIVE SPRINGS				
#358279	C=0.55-0.63	2 STRIPES	LONG	(STANDARD)
#358280	C=0.6-0.68	3 STRIPES	LONG	(OPTION)
#358281	C=0.65-0.7	4 STRIPES	LONG	(OPTION)

## BAGS



- 35 2460 PIVOT BALL 5.8 - V3 (10)
- 35 8019 COMPOSITE SET OF SHIMS FOR SHOCKS - V2 (2)
- 35 8020 COMPOSITE SHOCK PARTS
- 35 8032 SHOCK PISTON SET 8-HOLE (1.2; 1.3) 10-H. (1.1MM) - DELRIN - V2
- 35 8033 COMPOSITE SHOCK 6-HOLE PISTON SET (1.2; 1.3; 1.4MM) - DELRIN - V2
- 35 8040 HARDENED SHOCK SHIMS (4)
- 35 8041 STEEL SHOCK BUSHING (2)
- 35 8042 COMPOSITE SHOCK BUSHING & SHIM - V2 (2+2)
- 35 8053 XB8 ALU SHOCK CAP NUT - BLACK COATED (2)
- 35 8054 XB8 ALU SHOCK CAP NUT WITH VENT HOLE - BLACK COATED (2) (OPTION)
- 35 8074 FOLDING SHOCK BOOT (4)
- 35 8084 SHOCK RUBBER MEMBRANE BOTTOM RIBBED (4)

- 35 8124 XB8 ALU FRONT SHOCK BODY - HARD COATED (2)
- 35 8142 ALU SHOCK BODY NUT FOR SHOCK BOOT (2)
- 35 8150 ALU SHOCK BODY ADJ. NUT (2)
- 35 8162 FRONT SHOCK SHAFT (2)
- 35 8224 XB8 ALU REAR SHOCK BODY - HARD COATED (2)
- 35 8263 XB8 REAR SHOCK SHAFT (2)
- 35 8277 XRAY PROGRESSIVE SPRINGS - MEDIUM - 3 STRIPES - V2 (2)
- 35 8279 XRAY LONG PROGRESSIVE SPRINGS - SOFT-MEDIUM - 2 STRIPES - V2 (2)
- 96 0026 NUT M2.5 - SHORT (10)
- 97 0100 O-RING 10 x 1.5 (10)
- 97 0180 O-RING 18 x 1.8 (10)
- 97 1034 SILICONE O-RING 3.5x2 (10)

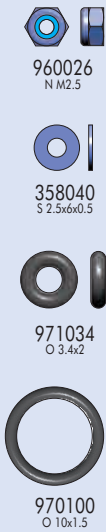

**NOTE**  
ORIENTATION

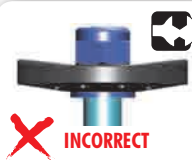
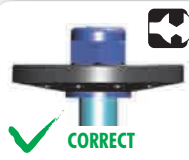
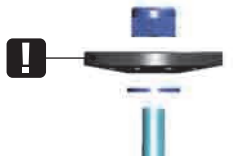

TIGHTEN GENTLY

DO NOT OVERTIGHTEN

The self-locking nut is gently tightened. The piston remains undistorted and fits inside the shock body perfectly, ensuring smooth movement of the piston.

The self-locking nut is overtightened, causing distortion of the piston. This will negatively affect the free movement of the piston in the shock body.

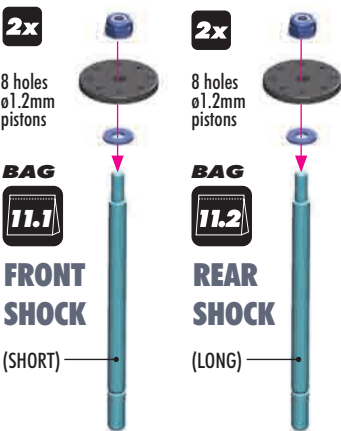

**FRONT SHOCK**

**REAR SHOCK**

(SHORT)

(LONG)



Grip the shock rod at top of exposed threads with side cutting pliers. Be careful not to damage the shock rod.



**2x** FRONT SHOCKS (SHORT)

**2x** REAR SHOCKS (LONG)

There are two different thickness shims, use them as shown. Use the same procedure when building both front and rear shocks.

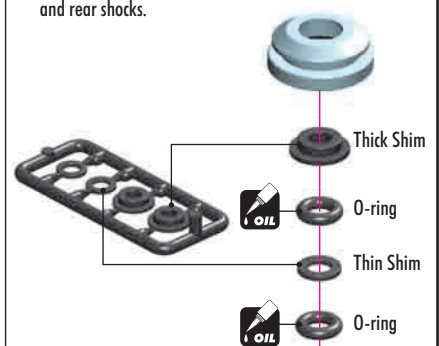

**DETAIL**

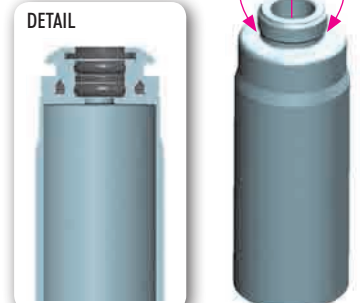

**SET-UP BOOK**

SHOCK DAMPING  
SHOCK PISTONS

# SHOCK ABSORBERS



970180  
Ø 18x1.8

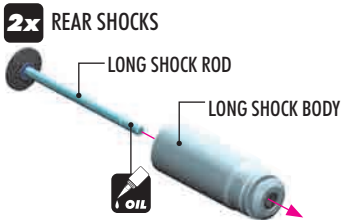
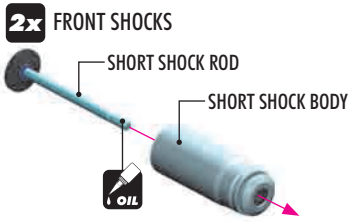

## EXTREMELY IMPORTANT

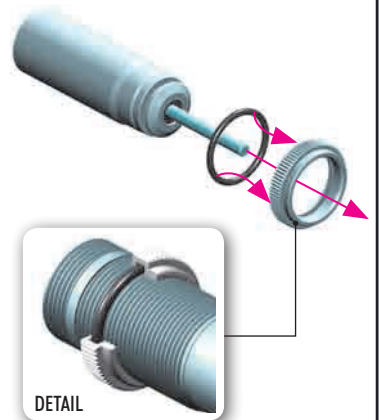
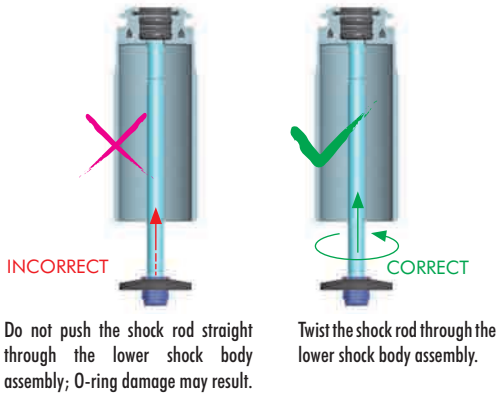

**2x FRONT SHOCKS**   **2x REAR SHOCKS**

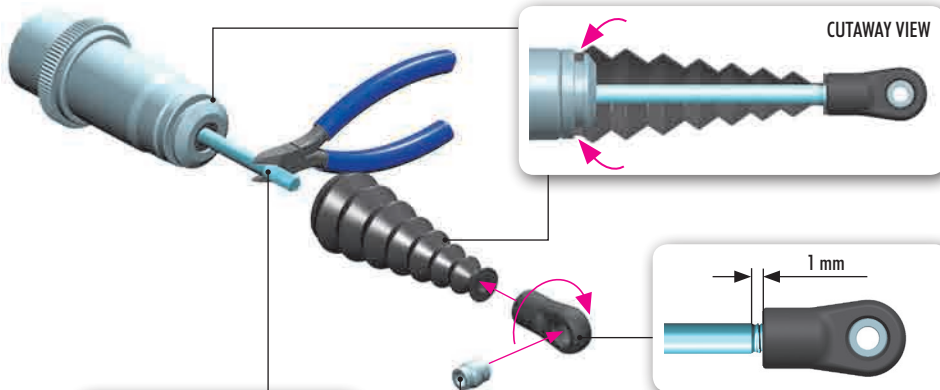

Grip the shock rod at top of exposed threads with side cutting pliers. Be careful not to damage the shock rod.

**TIP** Follow the TECH TIP on page 5 to install the pivot balls

## DEFAULT SHOCK REBOUND SETTING 0% (LOW REBOUND)

Follow the steps below to set the shock rebound to the default setting of 0%.

**2x FRONT (SHORT)**  
Oil 550cSt  
**2x REAR (LONG)**  
Oil 400cSt

**SET-UP BOOK**  
SHOCK OIL



**1** Extend the shock shaft completely. Fill the shock body with the shock oil. For the FRONT shocks (short) use 550cSt oil. For the REAR shocks (long) use 400cSt oil.



**2** Move the shock shaft up and down a few times to release the air bubbles trapped beneath the piston.



**3** Orient the filled shock vertically for several minutes with the shock shaft fully extended. The remaining air bubbles will release.



**4** Install the shock membrane into the groove in the upper shock cap.



**5** Gently place the shock cap assembly onto the filled shock body. Excess oil will spill from the shock. Screw the shock cap onto the body by only a few turns.



**6** Gently push the shock shaft completely into the shock body. Excess oil will flow through the hole in the shock cap.



**7** Keep the shock shaft pushed in the shock body and tighten the shock cap completely. The rebound will be at approximately 0%.

**2x REAR SHOCKS**

**2x FRONT SHOCKS**

LONG REAR SHOCKS

SHORT FRONT SHOCKS

LONG SPRING

SHORT SPRING

FRONT SHOCK PRELOAD

approx. 2mm

REAR SHOCK PRELOAD

approx. 2mm

**SET-UP BOOK**  
SPRING RATE  
SHOCK PRELOAD  
RIDE HEIGHT

**IMPORTANT!**  
Both rear shocks must be the same overall length.

**IMPORTANT!**  
Both front shocks must be the same overall length.

**IMPORTANT!**

FRONT & REAR SHOCKS

## TIP ALTERNATE SHOCK REBOUND SETTING (50% AND 100%)

The default shock rebound setting is 0% (as described on page 35). Alternatively, you may set the shock rebound setting to 50% or 100% as described below. Remove the shock springs before performing shock rebound adjustment.

### SETTING THE SHOCK REBOUND TO 50% (MEDIUM REBOUND)

**1 REMOVE SHOCK CAP**

Extend the shock shaft completely and remove the shock cap.

**2 OIL**

Fill the shock body with shock oil up to the top. Make sure to use same viscosity shock oil as is in the shock.

**3 OIL**

Orient the filled shock vertically for several minutes with the shock shaft fully extended. The remaining air bubbles will release.

**4 50%**

Gently place the shock cap assembly onto the filled shock body. Excess oil will spill from the shock.

**5 50%**

Push the shock shaft 50% into the shock body. Excess oil will bleed through the hole in the shock cap.

**6 100%**

Keep the shock shaft pushed 50% into the shock body and tighten the shock cap completely. The rebound will be at approximately 50%.

### SETTING THE SHOCK REBOUND TO 100% (HIGH REBOUND)

**1 REMOVE SHOCK CAP**

Extend the shock shaft completely and remove the shock cap.

**2 OIL**

Fill the shock body with shock oil up to the top. Make sure to use same viscosity shock oil as is in the shock.

**3 OIL**

Orient the filled shock vertically for several minutes with the shock shaft fully extended. The remaining air bubbles will release.

**4 100%**

Gently place the shock cap assembly onto the filled shock body. Keep the shock shaft extended 100% from the shock body and tighten the shock cap completely. The rebound will be at approximately 100%.

# 12. FINAL ASSEMBLY

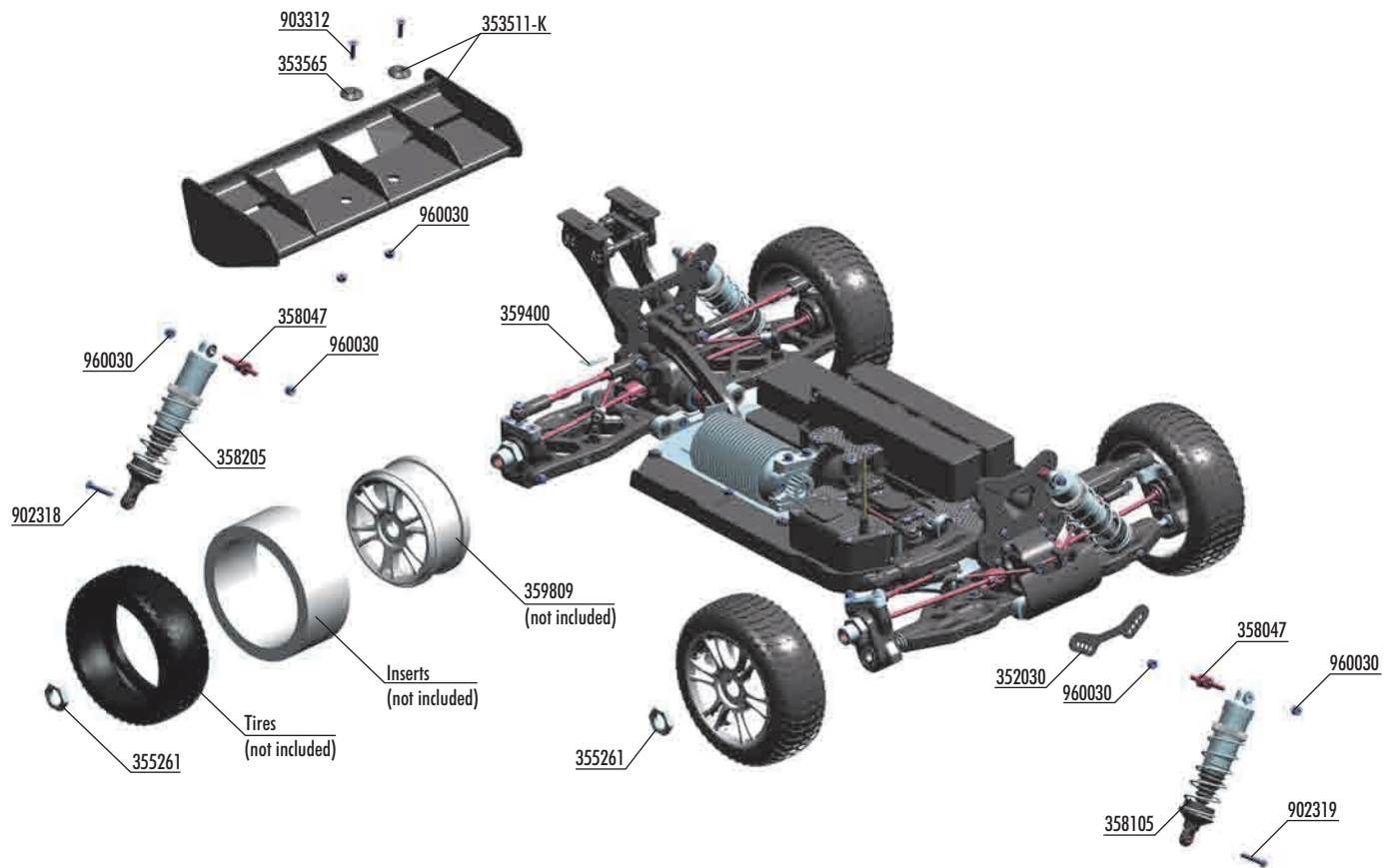

**BAG**

**12**

35 2030	XB8 FRONT SHOCK TOWER PROTECTOR	35 9400	BODY CLIP (10)
35 3511-K	XB8 REAR WING - BLACK	35 9709	XRAY XB8E BODY FOR 1/8 ELECTRIC BUGGY - LOW DOWNFORCE
35 3511	XB8 REAR WING - WHITE (OPTION)	35 9809	WHEELS STARBURST - YELLOW (4) (OPTION)
35 3511-Y	XB8 REAR WING - YELLOW (OPTION)		
35 3565	COMPOSITE REAR WING SHIM - BLACK (2)	90 2318	HEX SCREW SH M3x18 (10)
35 5261	WHEEL NUT - RIBBED - HARD COATED (2)	90 2319	HEX SCREW SH M3x18 - LEFT THREAD (10)
35 5265	WHEEL NUT WITH COVER - HARD COATED (2) (OPTION)	90 3312	HEX SCREW SFH M3x12 (10)
35 8047	STEEL SCREW SHOCK PIVOT BALL WITH HEX (2)	96 0030	NUT M3 (10)
35 8105	XB8 FRONT SHOCK ABSORBERS + BOOTS COMPLETE SET (2)		
35 8205	XB8 REAR SHOCK ABSORBERS + BOOTS COMPLETE SET (2)		

902318  
SH M3x18



902319  
SH M3x18  
LEFT thread



960030  
N M3

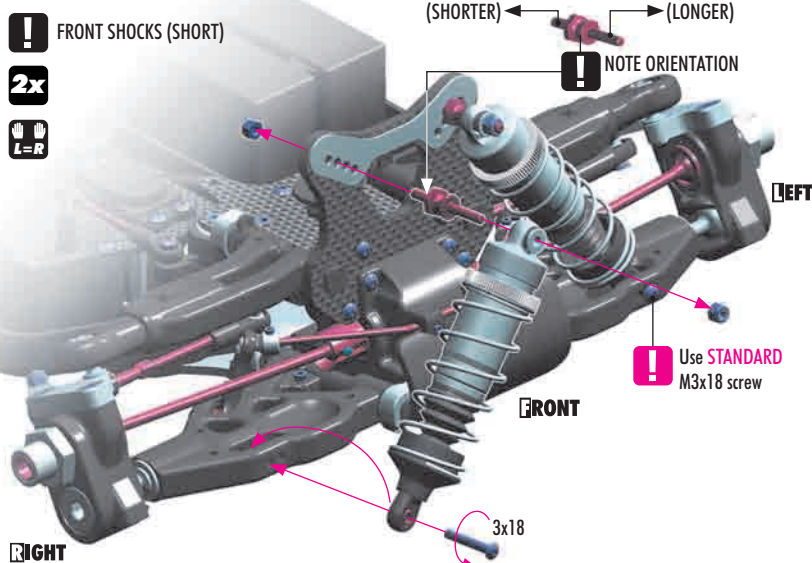

On the front right arm use the **SILVER** M3x18 screw - this screw has **LEFT THREAD** !

INITIAL SETTING

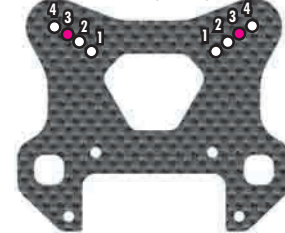

INITIAL SETTING



**SET-UP BOOK**

**SHOCK ABSORBERS**

902318  
M3x18



902319  
SH M3x18  
LEFT thread



960030  
N M3

## SET-UP BOOK

SHOCK ABSORBERS

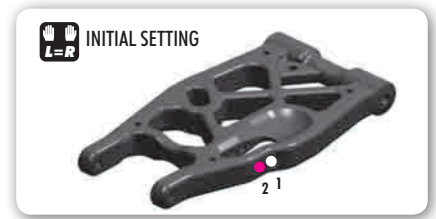
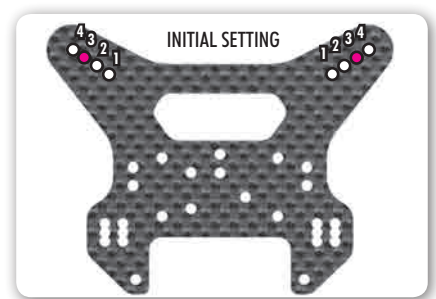
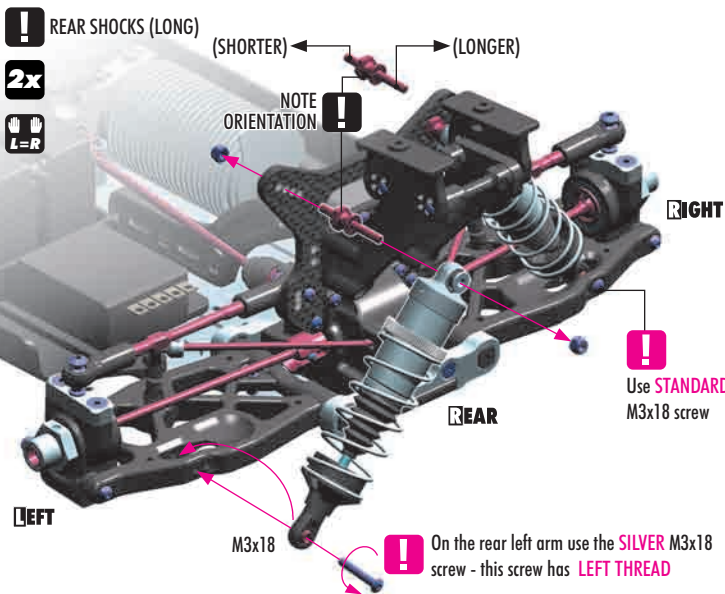

903312  
SFH M3x12



960030  
N M3

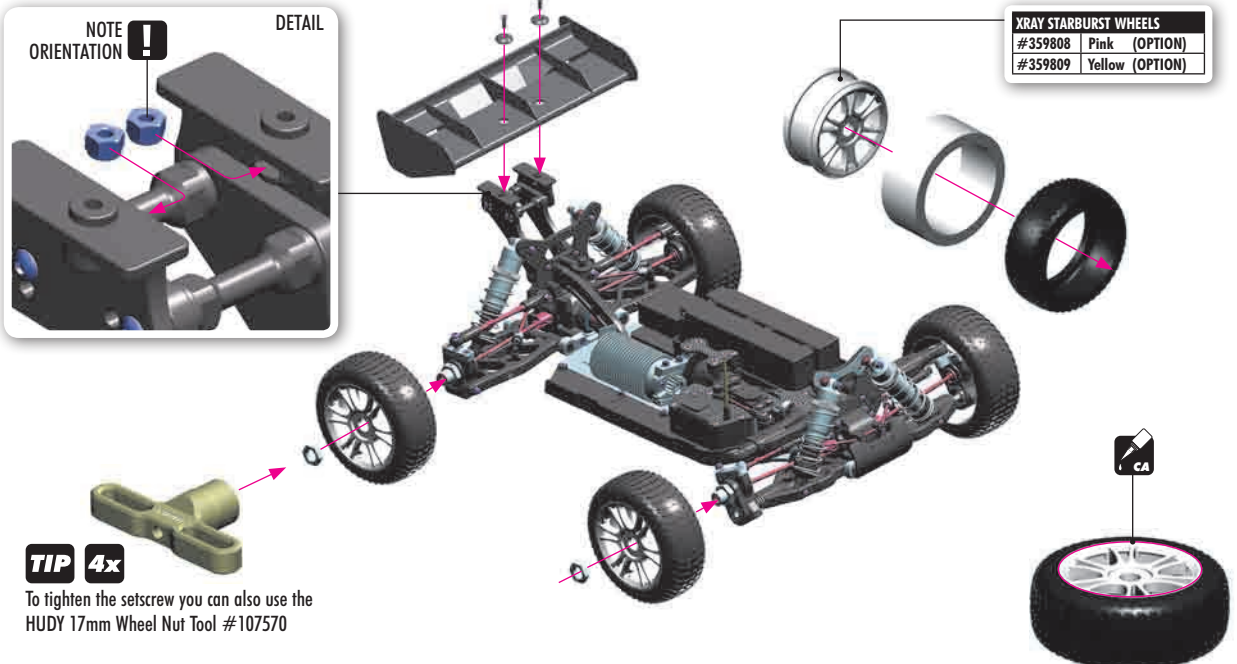

- Before cutting and making holes on the body, put the unpainted body on the chassis to confirm the mounting position and location for holes and cutouts.
- Before painting, wash the inside of the body with mild detergent, and then rinse and dry thoroughly.
- Mask all windows.
- Apply paint masks as appropriate.

- Paint the body using paints formulated for polycarbonate bodies.
- When the paint is dry, remove the masking.
- Carefully cut out the body using appropriate scissors or cutting tools.
- When you have finished cutting, peel off the external protective films.

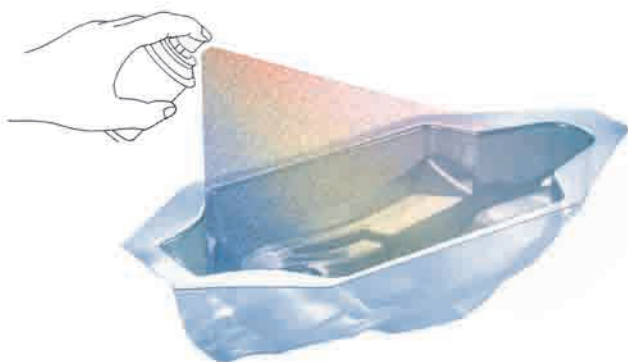

Body Reamer (HUDY #107600)

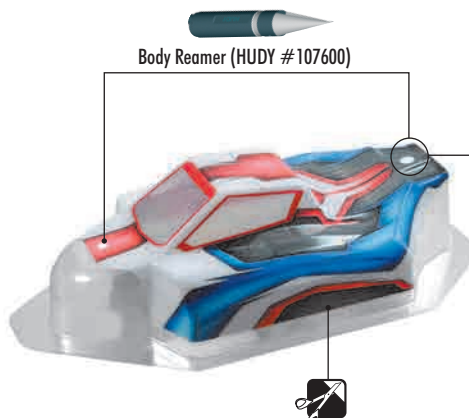

Ensure to make this rear body mount hole oval so in the case of chassis flex after a big jump the body mount will not tear up the hole.

# TROUBLESHOOTING GUIDE

PROBLEM	CAUSE	SOLUTION
CAR IS HARD TO CONTROL	<ul style="list-style-type: none"> <li>• Weak transmitter and/or receiver batteries</li> <li>• Low reception from radio antennas</li> <li>• Servo linkages not adjusted properly</li> </ul>	<ul style="list-style-type: none"> <li>• Recharge or replace batteries</li> <li>• Fully extend transmitter and receiver antennas</li> <li>• Move servo to neutral then re-adjust linkage(s)</li> </ul>
STEERING DOES NOT WORK PROPERLY	<ul style="list-style-type: none"> <li>• Weak transmitter and/or receiver batteries</li> <li>• Bent linkages or driveshafts</li> <li>• Loose steering components</li> <li>• Drivetrain damage</li> </ul>	<ul style="list-style-type: none"> <li>• Recharge or replace batteries</li> <li>• Check tightness of steering components and tighten if necessary</li> <li>• Replace damaged parts</li> </ul>
HANDLING PROBLEMS	<ul style="list-style-type: none"> <li>• Shocks are not working properly</li> <li>• Suspension is binding</li> <li>• Improper tires</li> </ul>	<ul style="list-style-type: none"> <li>• Rebuild the shocks and replace worn or broken parts</li> <li>• Make sure suspension moves freely. Replace worn or broken parts</li> <li>• Use different tires</li> </ul>
STEERING FEELS SLUGGISH OR VAGUE	<ul style="list-style-type: none"> <li>• Suspension is binding</li> <li>• Damaged steering servo</li> </ul>	<ul style="list-style-type: none"> <li>• Make sure suspension moves freely, and replace worn or broken parts</li> <li>• Check the steering servo for damage and wear, and replace/repair if necessary</li> </ul>
THE CAR DOES NOT DRIVE STRAIGHT	<ul style="list-style-type: none"> <li>• Suspension is binding</li> <li>• Steering trim is off-center</li> <li>• Wheels are loose</li> <li>• Damaged steering servo</li> </ul>	<ul style="list-style-type: none"> <li>• Make sure suspension moves freely, and replace worn or broken parts</li> <li>• Adjust steering trim until car drives straight</li> <li>• Check the make sure the wheel nuts are properly tightened</li> <li>• Check the steering servo for damage and wear, and replace/repair if necessary</li> </ul>

## SHOCK MAINTENANCE

The most important maintenance task for keeping consistent shock performance is refilling and bleeding them correctly. If built correctly, it will not be necessary to re-build them often. Replacing warped/hard rubber bladders and o-rings, scarred piston rods, or shaved/split/loose composite upper and lower ball joints are also important.

- For club racing, it is recommended to check the shocks for air inside before each race and only re-fill and bleed them if necessary. Before each race day, make sure you take the spring off of each shock, hold it up to your ear, and quickly compress the shock rod fully into the body while listening for any air making a "whistling" or "squishy" sound as it passes through the piston holes. If you hear any air, refill and bleed your shocks. For high-competition racing, it is recommended that the shocks be re-filled and bled before a large event.
- If building or pairing new shocks, always make sure they are the same length using a shock length measuring tool and adjust the lower ball joints as needed.
- If installing new rubber bladders, carefully trim the thin excess rubber from the edges of their lips. Curved body scissors work the best.
- Regularly inspect the amount of dirt on the felt protector in the shocks (if present) and regularly replace with a new one.
- During regular shock operation, oil naturally gets on the shock shaft and drop-by-drop slightly gets out of the shock body. Shocks should be inspected regularly after each race, and oil replaced as required.

## BEARING MAINTENANCE

Ball-bearings in an off-road car or truggy must be properly maintained for smooth operation and long lifespan.

Typically, the ball-bearings included in new cars are greased for highest lifespan and as such the drivetrain may not seem to be as free as with lightly-oiled ball-bearings. However, when the car is run the ball-bearings will become more free and the drivetrain will become very efficient.

There are several types of bearings discussed here: bearings which already come greased from the factory, bearings which must be lubricated using the HUDY Bearing Grease, and then there are also bearings in the steering system which need to be lubricated with HUDY Bearing Oil.

The following procedures are recommended to clean all of the bearings in your off-road car or truggy. For high-competition racing, we recommended doing this every 3-4 weeks, or before a major race.

1. Remove the seals on both sides of the bearing (if present). If the seals bend a little and you can see a kink, carefully flatten the kink out by hand.
2. Spray the seals with motor cleaner and blow dry with compressed air.
3. Spray the bearing on both sides with motor cleaner.
4. Spin the bearing while it is still wet to dislodge any particles with the cleaner.
5. Spray the bearing on both sides again.
6. Blow both sides of the bearing dry with compressed air to make sure particles come out.
7. Hold the inner part of the bearing with my left thumb/forefinger and spin it to make sure it spins free without any abnormal vibrations or sounds.
8. Place one drop of bearing oil into each side of the bearing.
9. Replace both seals at the same time by lining them up on each side of the bearing and lightly pressing them in all the way around the bearings circumference with your thumb and forefinger. Do not press too hard or use any type of tool, such as a wrench tip, to push the blue seals in as they will push in too far, bend and cause drag.

If you spin test the bearing after you have re-oiled and sealed it, it will not spin freely for an extended period of time. The lightest of oils may allow it to spin for 1-2 seconds. This is normal and once you have mounted the bearings in the car again, the drive train will spin freely.

Make sure you use a motor cleaner that does not leave a residue after it dries as this may cause drag and wear in the bearings.

### RECOMMENDED PRODUCTS

- Use HUDY Bearing Grease to regularly lubricate grease-bearing ball-bearings.
- Use HUDY Bearing Oil to lubricate the bearings of the steering system.

HUDY #106220



HUDY #106222



HUDY #106221



HUDY #106230



## SUSPENSION & DRIVETRAIN MAINTENANCE

- Check suspension for free movement during building and operation, and especially after running and if you have crashed the car. If the suspension does not move freely, use the appropriate HUDY Arm Reamer to clean and resize the holes of the suspension arms.
- Regularly check the drive shaft pins (both side and center) and if they show any wear must be immediately replaced by new pins. If the car is run with worn pins, excessive wear on the diff outdrives will result. The 106000 HUDY Drive Pin Replacement Tool (for 3mm Pins) is a compact, rugged multi-use tool set for replacing 3mm drive pins in drive shafts. Use the HUDY replacement drive shaft pins 3x14 (#106050).
- Regularly inspect and replace the connecting pins which connect the center drive shafts with the pinion gear, and also the pins that connect the wheel drive shafts with wheel axles. Use HUDY Graphite Grease to lubricate the drive shaft connecting joints and the diff gears.
- Pivot balls and ball-joints will naturally wear for some time and will generate play. If there is too much play the pivot balls and ball joints need to be replaced.
- If the car is run in wet conditions, apply WD-40® on all drivetrain parts before the run. After the run, clean and dry the parts again.

HUDY #106210



## HUDY SPRING STEEL™

The HUDY Spring Steel™ used in the car is the strongest and most durable steel material on the RC market. While items made from HUDY Spring Steel™ are still subject to wear, the lifespan is considerably longer than any other material. As parts made from HUDY Spring Steel™ wear, the brown color will after some time "go down" but it will not affect the strength of the material. The brown color is only a surface treatment and if the brown color will wear the durability of the part will be still strong.

**[www.teamxray.com](http://www.teamxray.com)**

**XRAY EUROPE**

XRAY, K VÝSTAVISKU 6992, 91101 TRENCIN, SLOVAKIA, EUROPE  
PHONE: +421-32-740 11 00, FAX: +421-32-740 11 09, [info@teamxray.com](mailto:info@teamxray.com)

**XRAY USA**

RC AMERICA, 2030 Century Center Blvd #15, Irving, TX 75062, USA  
PHONE: 214-744-2400, FAX: 214-744-2401, [xray@rcamerica.com](mailto:xray@rcamerica.com)